



Cartridge and CRS Product Catalogue

DYNALENE
Tomorrow's Solutions Flow Through Us



TABLE OF CONTENTS

IC Series (Low conductivity (Fuel Cell / Electronics Cooling / Laser Cooling)	3
Features and specification	3
Design and construction / Ordering information	4
Hydraulic property: DI Water	7
Hydraulic property: LC EG	9
Hydraulic property: LC PG	19

CR Series (Contamination Removal)	29
Series overview: Cartridge and Large scale contamination removal	29
General information: Contaminant overview	29
Design and construction / Ordering information	33
Hydraulic property: DI Water	35

DYI Series	36
Series overview	36
Laboratory Scale Deionized Water	36
Industrial Scale Deionized Water	38

Glycol Regeneration	39
Introduction	39

IC Series Cartridge

Series Overview

IC Series ion exchange cartridge offered by Dynalene is designed and extensively tested for greater ion removal for our low conductivity heat transfer fluid products. These cartridges can be easily installed to systems operating up to 200°F (93°C). We offer two cartridge models, IC-070 and IC-093, which are designed to operate up to 158°F (70°C) and 200°F (93°C), respectively. Our resin cartridge products, which are currently used in low conductivity cooling applications such as fuel cell and battery cooling, can be custom designed for your systems.

Features

- Wide range operational temperature
- High capacity media
- Performance tested for a long operating cycle
- Inhibitor retaining capacity
- Longer life
- Option of barb and FNPT connections
- Compatible with glycol based heat transfer fluid
- Resistant to physical and chemical deterioration
- Spin welded construction
- Easy to install
- Easy to custom design



Applications

- Fuel cell cooling
- Battery cooling
- Electronics cooling
- Computer cooling
- Laser cooling
- All applications that requires low electrical conductivity of the fluid over the time of operation

Specifications

Properties	Value
Max. operating temperature	IC-070: 158°F (70°C) IC-093: Intermittent 200°F (93°C) Continuous 185°F (85°C)
Material of construction	Polypropylene
Max. operating pressure	40 psi
Orientation	Vertical
Media	Ion exchange resin
Connection Type	FNPT and Barb
Connector Configuration	Round and Hex

Exchange capacity	
Product number	Capacity (meq)
IC-070-04	147
IC-093-04	203
IC-070-06	190
IC-093-06	262
IC-093-08	1273
IC-093-16	2865
IC-093-24	4377

Customization

IC Series Cartridge

Design and Construction

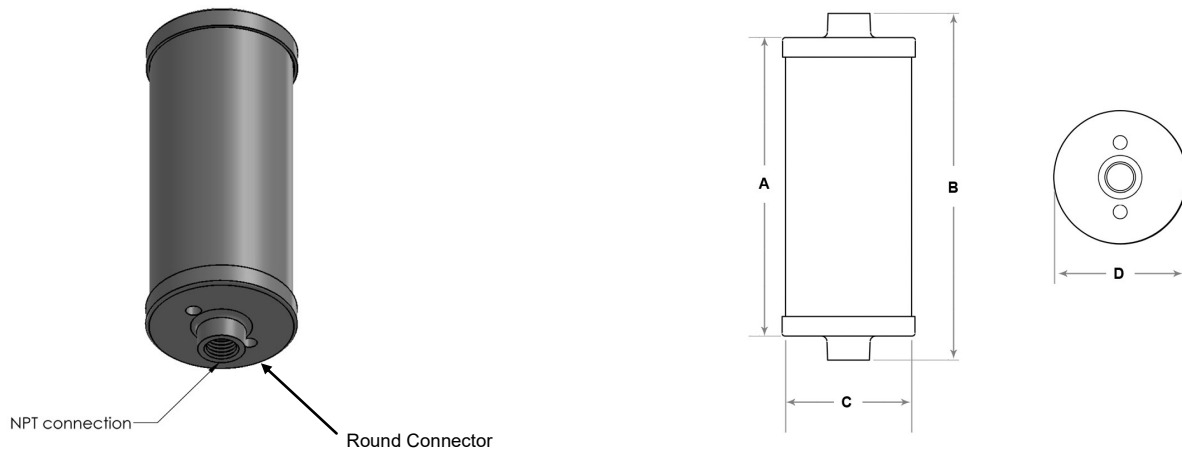

The round connector on the IC series cartridge features two different maximum operating temperatures (70°C or 93°C). The easy install vertical orientation has a maximum pressure of 40 psi.

IC-070 Series Round Connector Cartridge Dimensions, Weight, and Flow Rate Compatibility

Cartridge I.D./ Size	A (inch)	B (inch)	C (inch)	D (inch)	Weight (lbs)	Connector Config.	Connection Type	Connection Size (inch)	Max Operating Temp (°C)	Max Flow Rate (GPM)	Max Pressure (psi)
IC-070-04	4.5	5.5	2.3	2.4	0.46	Round	FNPT	0.25	70	1.0	40
IC-070-06	5.5	6.5	2.3	2.4	0.65	Round	FNPT	0.25	70	1.3	40

IC-093 Series Round Connector Cartridge Dimensions, Weight, and Flow Rate Compatibility

Cartridge I.D./ Size	A (inch)	B (inch)	C (inch)	D (inch)	Weight (lbs)	Connector Config.	Connection Type	Connection Size (inch)	Max Operating Temp (°C)	Max Flow Rate (GPM)	Max Pressure (psi)
IC-093-04	4.5	5.5	2.3	2.4	0.46	Round	FNPT	0.25	93	1.0	40
IC-093-06	5.5	6.5	2.3	2.4	0.65	Round	FNPT	0.25	93	1.3	40

IC Series Cartridge

Design and Construction

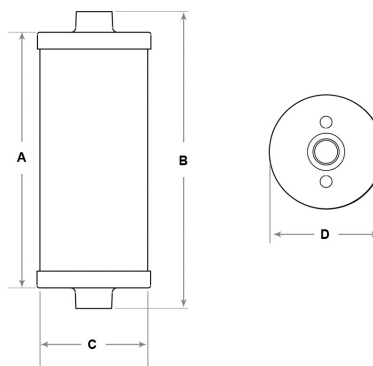
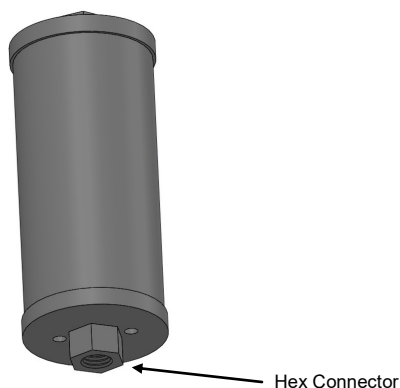

The hex connector on the IC series cartridge features two different maximum operating temperatures (70°C or 93°C). The easy install vertical orientation has a maximum pressure of 40 psi, and comes in a variety of

IC-070 Series Hex Connector Cartridge Dimensions, Weight, and Flow Rate Compatibility

Cartridge I.D./ Size	A (inch)	B (inch)	C (inch)	D (inch)	Weight (lbs)	Connector Config.	Connection Type	Connection Size (inch)	Max Operating Temp (°C)	Max Flow Rate (GPM)	Max Pressure (psi)
IC-070-04H	4.5	5.5	2.3	2.4	0.46	Hex	FNPT	0.25	70	1.0	40
IC-070-06H	5.5	6.0	2.3	2.4	0.65	Hex	FNPT	0.25	70	1.3	40
IC-070-08H	7.5	8.5	4.3	4.5	2.50	Hex	FNPT	0.50	70	2.0	40
IC-070-10H	9.5	10.5	4.3	4.5	3.33	Hex	FNPT	0.50	70	2.0	40
IC-070-12H	11.5	12.5	4.3	4.5	4.17	Hex	FNPT	0.50	70	2.0	40
IC-070-14H	13.5	14.5	4.3	4.5	5.00	Hex	FNPT	0.50	70	2.3	40
IC-070-16H	15.5	16.5	4.3	4.5	6.10	Hex	FNPT	0.50	70	2.5	40
IC-070-18H	17.5	18.5	4.3	4.5	6.98	Hex	FNPT	0.50	70	2.8	40
IC-070-20H	19.5	20.5	4.3	4.5	7.85	Hex	FNPT	0.50	70	3	40
IC-070-22H	21.5	22.5	4.3	4.5	8.73	Hex	FNPT	0.50	70	3.2	40
IC-070-24H	23.5	24.5	4.3	4.5	9.60	Hex	FNPT	0.50	70	3.4	40

IC-093 Series Hex Connector Cartridge Dimensions, Weight, and Flow Rate Compatibility

Cartridge I.D./ Size	A (inch)	B (inch)	C (inch)	D (inch)	Weight (lbs)	Connector Config.	Connection Type	Connection Size (inch)	Max Operating Temp (°C)	Max Flow Rate (GPM)	Max Pressure (psi)
IC-093-04H	4.5	5.5	2.3	2.4	0.46	Hex	FNPT	0.25	93	1.0	40
IC-093-06H	5.5	6.0	2.3	2.4	0.65	Hex	FNPT	0.25	93	1.3	40
IC-093-08H	7.5	8.5	4.3	4.5	2.50	Hex	FNPT	0.50	93	2.0	40
IC-093-10H	9.5	10.5	4.3	4.5	3.33	Hex	FNPT	0.50	93	2.0	40
IC-093-12H	11.5	12.5	4.3	4.5	4.17	Hex	FNPT	0.50	93	2.0	40
IC-093-14H	13.5	14.5	4.3	4.5	5.00	Hex	FNPT	0.50	93	2.3	40
IC-093-16H	15.5	16.5	4.3	4.5	6.10	Hex	FNPT	0.50	93	2.5	40
IC-093-18H	17.5	18.5	4.3	4.5	6.98	Hex	FNPT	0.50	93	2.8	40
IC-093-20H	19.5	20.5	4.3	4.5	7.85	Hex	FNPT	0.50	93	3	40
IC-093-22H	21.5	22.5	4.3	4.5	8.73	Hex	FNPT	0.50	93	3.2	40
IC-093-24H	23.5	24.5	4.3	4.5	9.60	Hex	FNPT	0.50	93	3.4	40

IC Series Cartridge

Design and Construction

Angle	I.D.
0°	0
90°	1
180°	2

Model	Temperature	Size	Angle I.D.
IC	93	08B	2

Example of ordering a barbed connection with a 180° connection angle.

The barbed connector on the IC series cartridge features two different maximum operating temperatures (70°C or 93°C). The smaller cartridges offer vertical barb orientation, while the larger cartridges offer customization on the orientation of the barbs. The cartridges have a maximum pressure rating of 40 psi and come in a variety of lengths.

IC-070 Series Barbed Connector Cartridge Dimensions, Weight, and Flow Rate Compatibility

Cartridge I.D./ Size	A (inch)	B (inch)	C (inch)	D (inch)	Weight (lbs)	Connection Type	Tube Size (inch)	Connector Direction	Angle Between Connector	Max Operating Temp (°C)	Max Flow Rate (GPM)	Max Pressure (psi)
IC-070-04BX	4.8	7.1	2.3	2.4	0.46	Barbed	3/8	0°	-	70	1.0	40
IC-070-06BX	5.2	7.6	2.3	2.4	0.65	Barbed	3/8	0°	-	70	1.3	40
IC-070-08BX	7.5	11.0	4.3	4.5	2.50	Barbed	1/2	90°	0,1,2	70	2.0	40
IC-070-10BX	9.5	12.5	4.3	4.5	3.33	Barbed	1/2	90°	0,1,2	70	2.0	40
IC-070-12BX	11.5	14.5	4.3	4.5	4.17	Barbed	1/2	90°	0,1,2	70	2.0	40
IC-070-14BX	13.5	16.5	4.3	4.5	5.00	Barbed	1/2	90°	0,1,2	70	2.3	40
IC-070-16BX	15.5	18.5	4.3	4.5	6.10	Barbed	1/2	90°	0,1,2	70	2.5	40
IC-070-18BX	17.5	20.5	4.3	4.5	6.98	Barbed	1/2	90°	0,1,2	70	2.8	40
IC-070-20BX	19.5	22.5	4.3	4.5	7.85	Barbed	1/2	90°	0,1,2	70	3	40
IC-070-22BX	21.5	24.5	4.3	4.5	8.73	Barbed	1/2	90°	0,1,2	70	3.2	40
IC-070-24BX	23.5	26.5	4.3	4.5	9.60	Barbed	1/2	90°	0,1,2	70	3.4	40

IC-093 Series Barbed Connector Cartridge Dimensions, Weight, and Flow Rate Compatibility

Cartridge I.D./ Size	A (inch)	B (inch)	C (inch)	D (inch)	Weight (lbs)	Connection Type	Tube Size (inch)	Connector Direction	Angle Between Connector	Max Operating Temp (°C)	Max Flow Rate (GPM)	Max Pressure (psi)
IC-093-04BX	4.8	7.1	2.3	2.4	0.46	Barbed	3/8	0°	-	93	1.0	40
IC-093-06BX	5.2	7.6	2.3	2.4	0.65	Barbed	3/8	0°	-	93	1.3	40
IC-093-08BX	7.5	11.0	4.3	4.5	2.50	Barbed	1/2	90°	0,1,2	93	2.0	40
IC-093-10BX	9.5	12.5	4.3	4.5	3.33	Barbed	1/2	90°	0,1,2	93	2.0	40
IC-093-12BX	11.5	14.5	4.3	4.5	4.17	Barbed	1/2	90°	0,1,2	93	2.0	40
IC-093-14BX	13.5	16.5	4.3	4.5	5.00	Barbed	1/2	90°	0,1,2	93	2.3	40
IC-093-16BX	15.5	18.5	4.3	4.5	6.10	Barbed	1/2	90°	0,1,2	93	2.5	40
IC-093-18BX	17.5	20.5	4.3	4.5	6.98	Barbed	1/2	90°	0,1,2	93	2.8	40
IC-093-20BX	19.5	22.5	4.3	4.5	7.85	Barbed	1/2	90°	0,1,2	93	3	40
IC-093-22BX	21.5	24.5	4.3	4.5	8.73	Barbed	1/2	90°	0,1,2	93	3.2	40
IC-093-24BX	23.5	26.5	4.3	4.5	9.60	Barbed	1/2	90°	0,1,2	93	3.4	40

IC Series Cartridge

Hydraulic Properties: DI Water

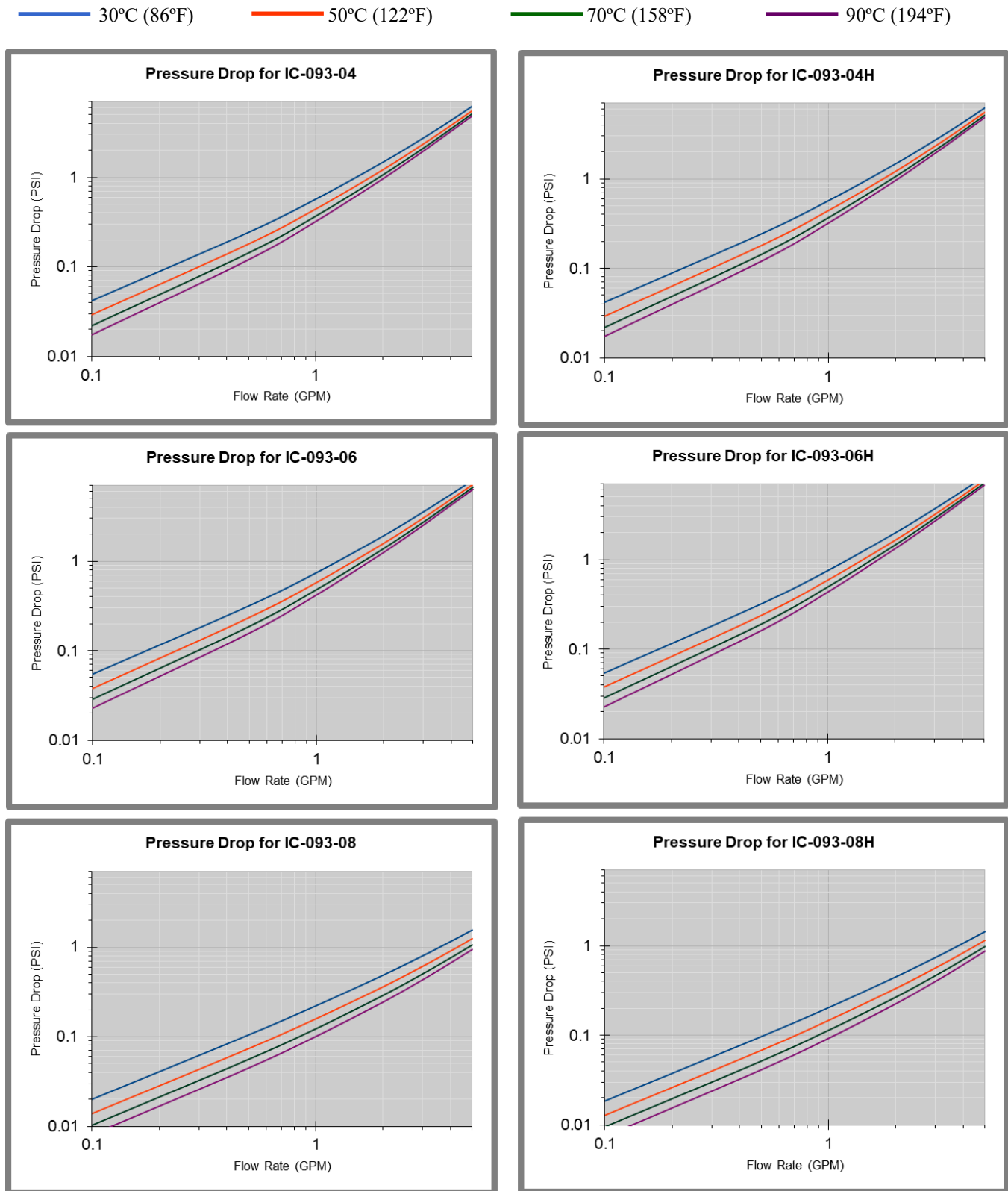

Note: Pressure drop was determined with deionized water.

IC Series Cartridge

Hydraulic Properties: DI Water

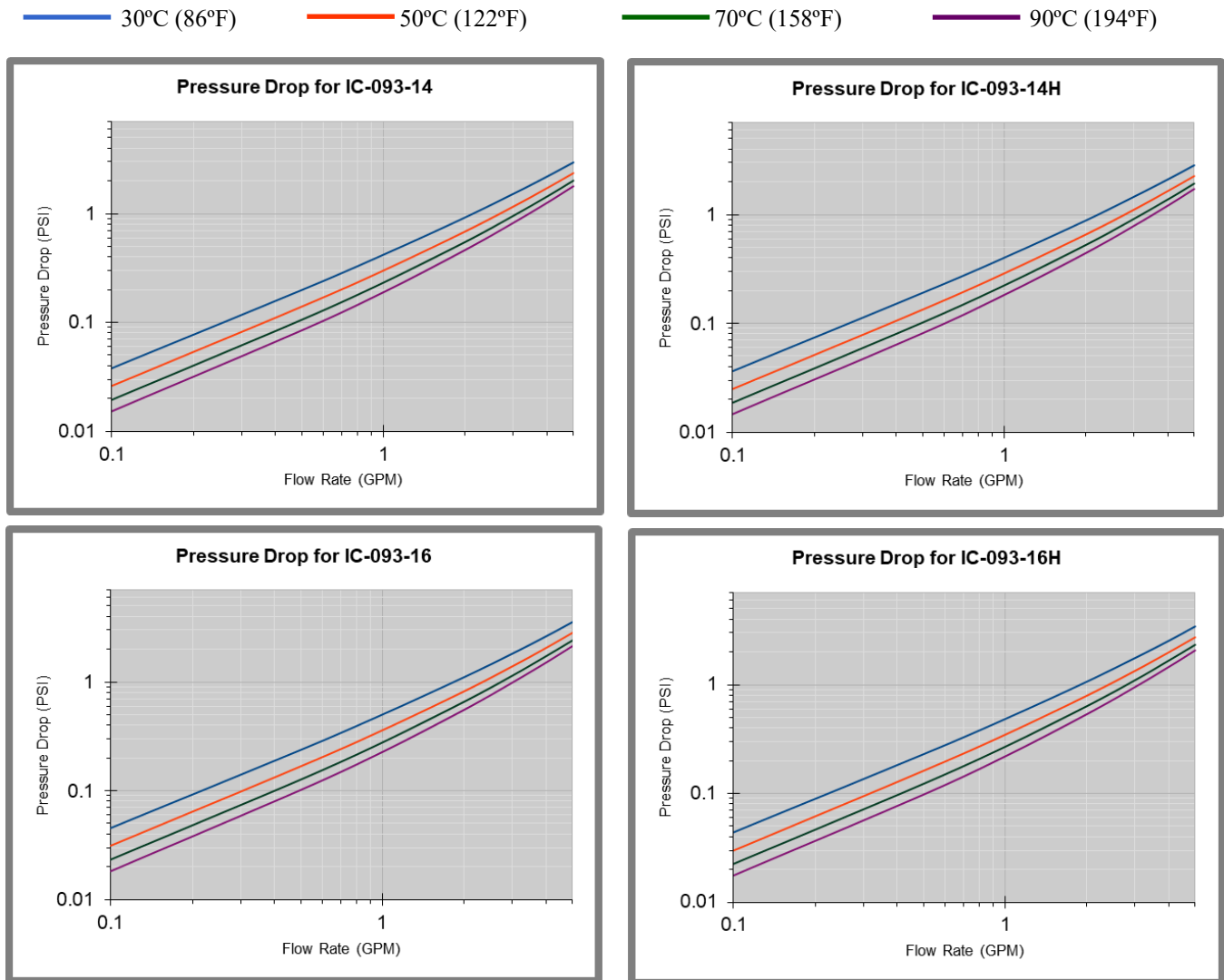

Note: Pressure drop was determined with deionized water.

IC Series Cartridge

Hydraulic Properties: Low Conductivity Ethylene Glycol 20% (LC-EG 20%)

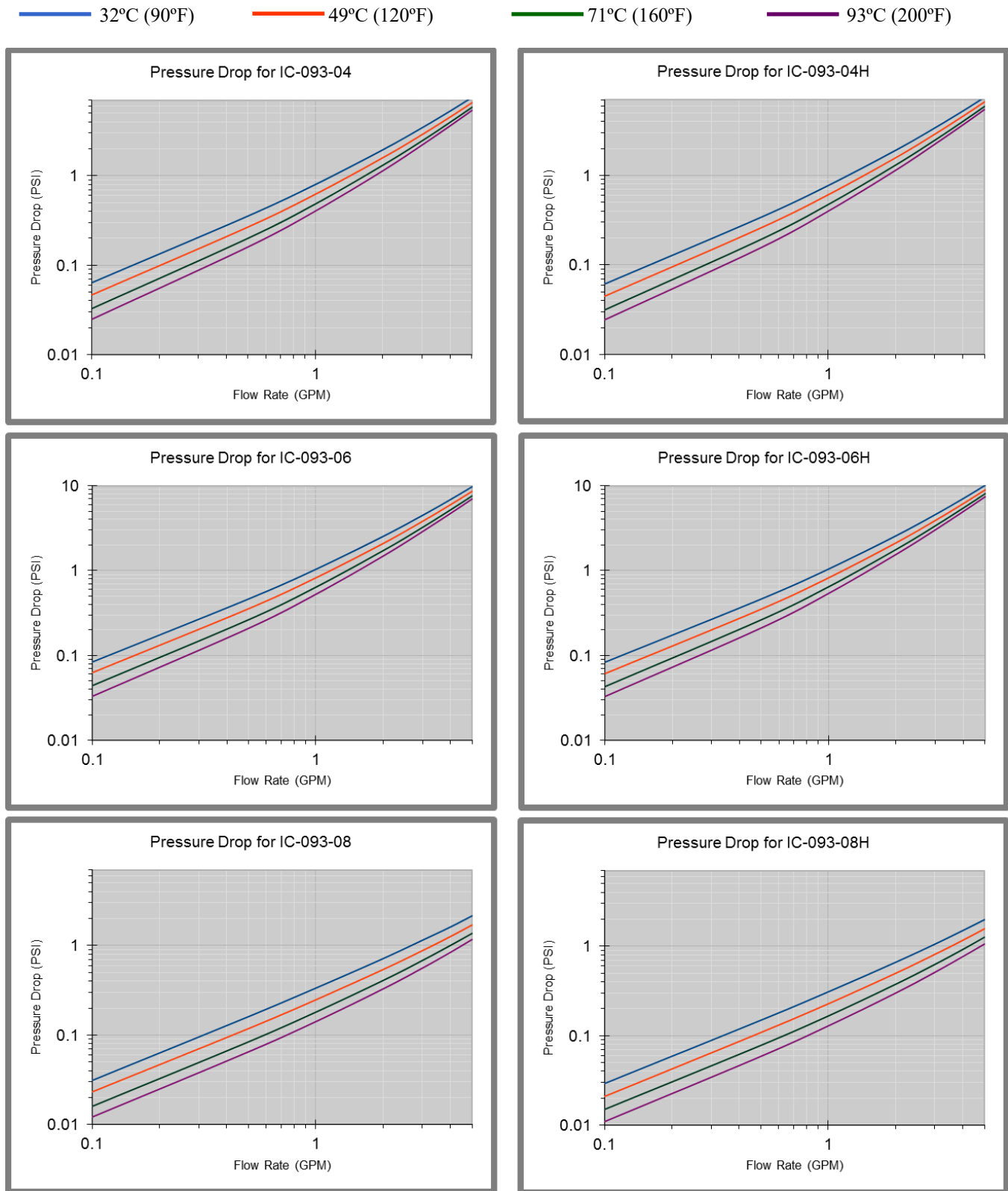

IC Series Cartridge

Hydraulic Properties: Low Conductivity Ethylene Glycol 20% (LC-EG 20%)

— 32°C (90°F) — 49°C (120°F) — 71°C (160°F) — 93°C (200°F)

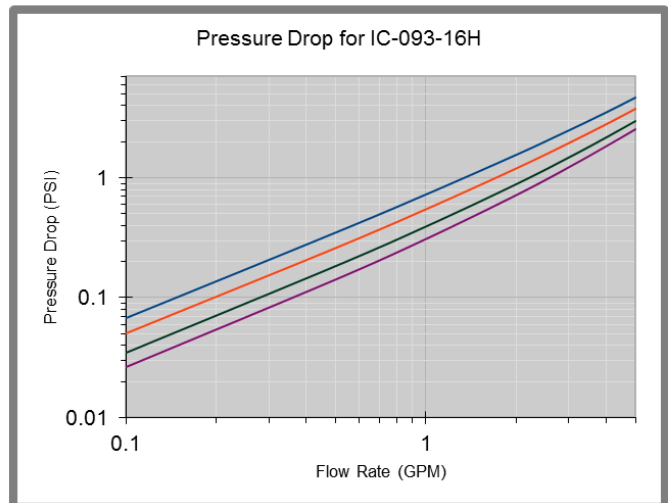
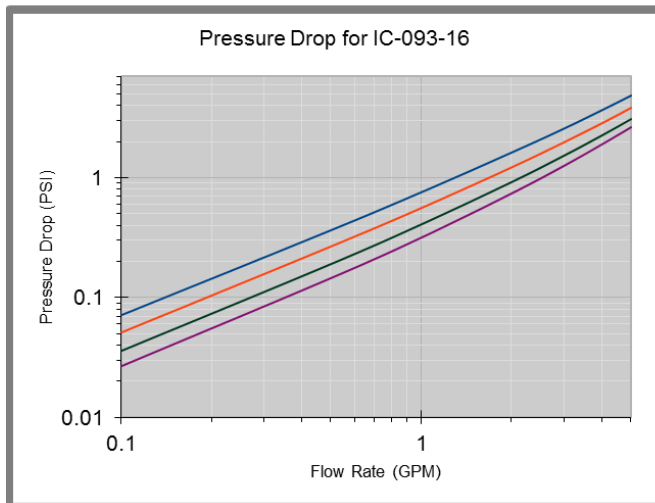
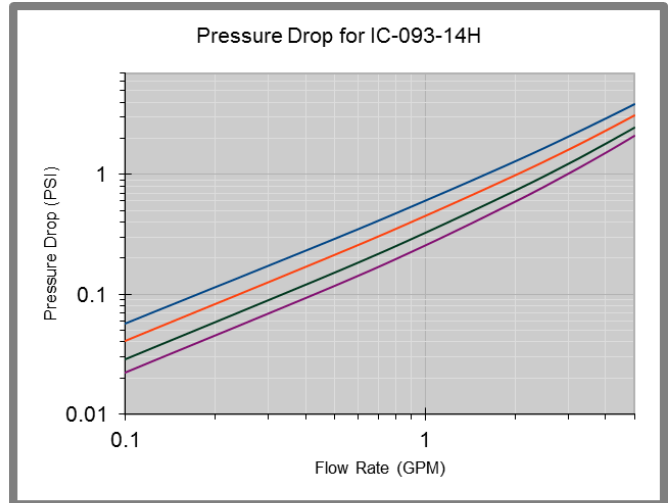
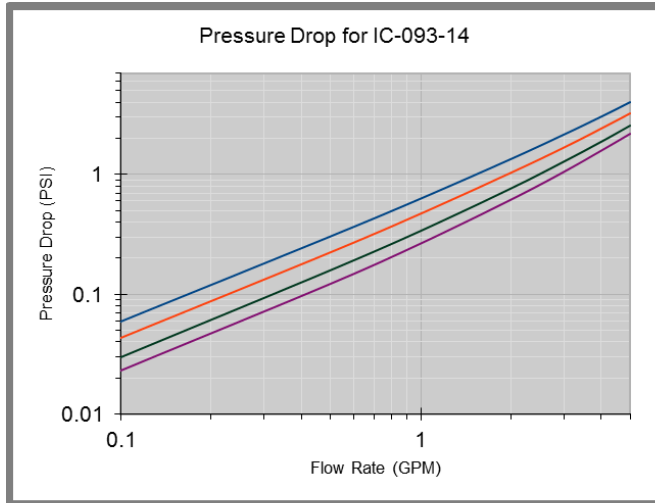

IC Series Cartridge

Hydraulic Properties: Low Conductivity Ethylene Glycol 30% (LC-EG 30%)

— 32°C (90°F) — 49°C (120°F) — 71°C (160°F) — 93°C (200°F)

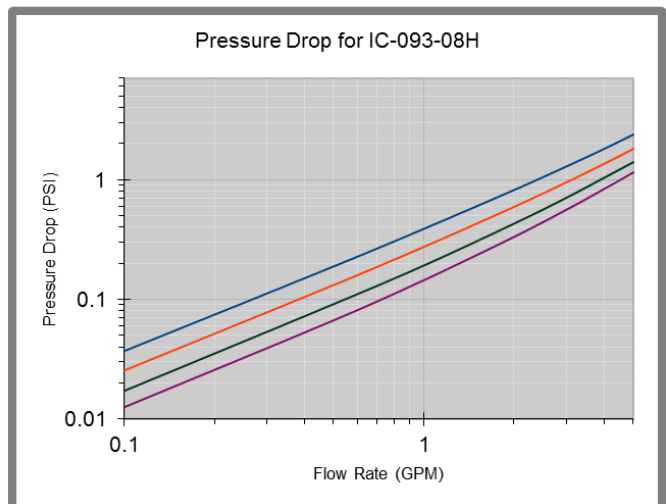
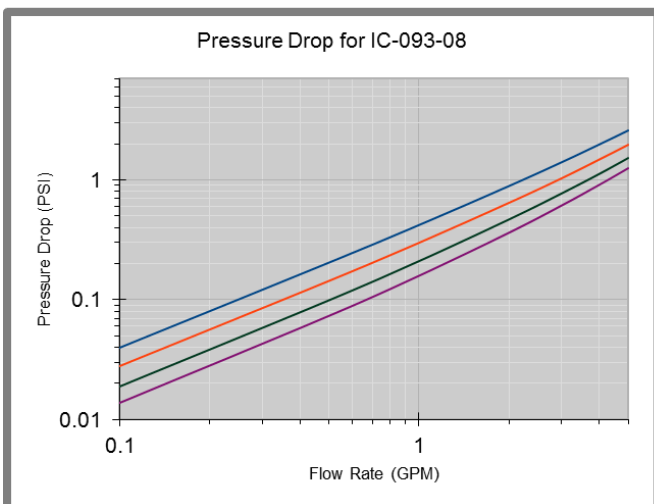
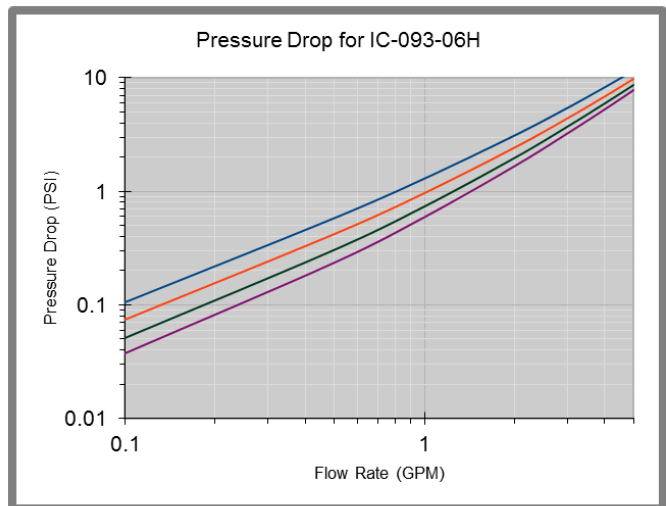
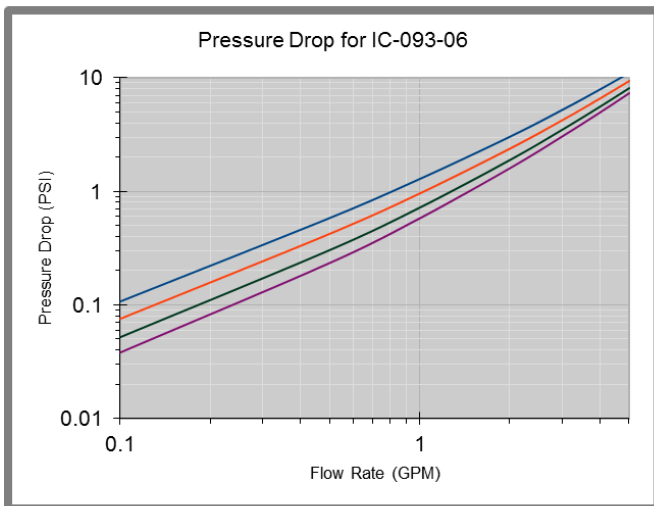
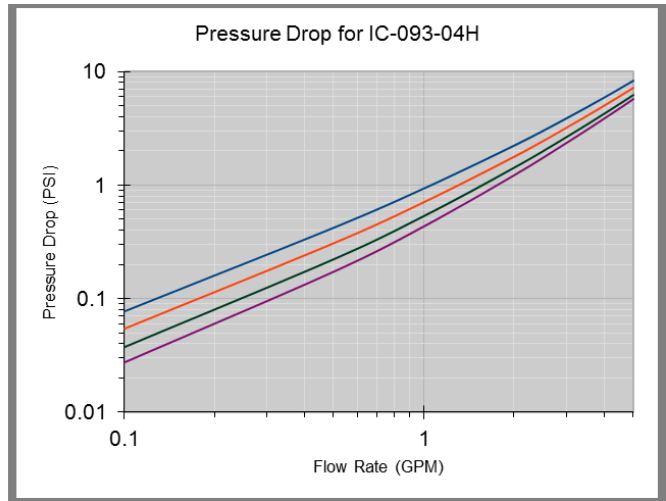
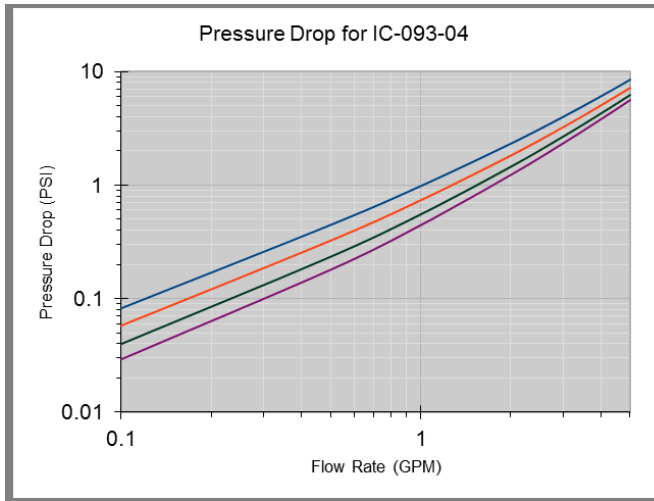

IC Series Cartridge

Hydraulic Properties: Low Conductivity Ethylene Glycol 30% (LC-EG 30%)

— 32°C (90°F) — 49°C (120°F) — 71°C (160°F) — 93°C (200°F)

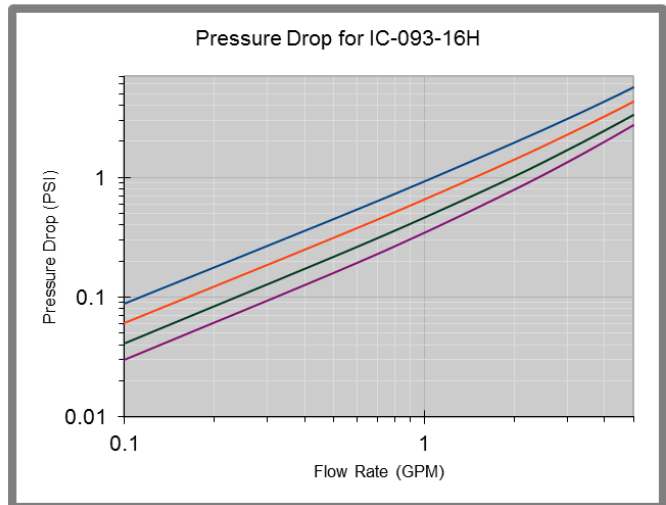
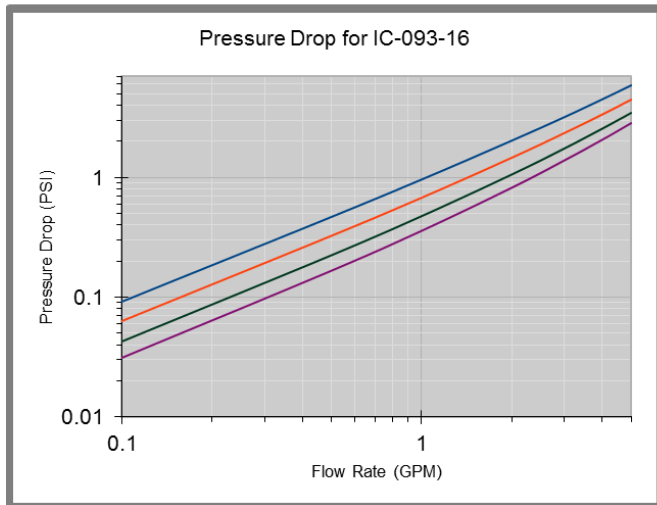
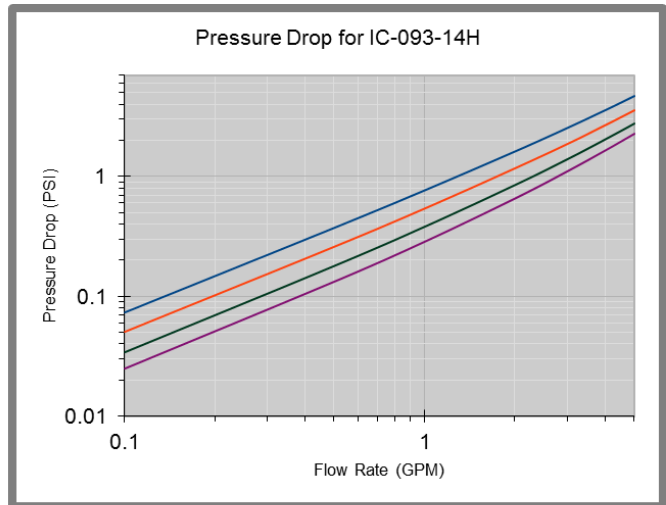
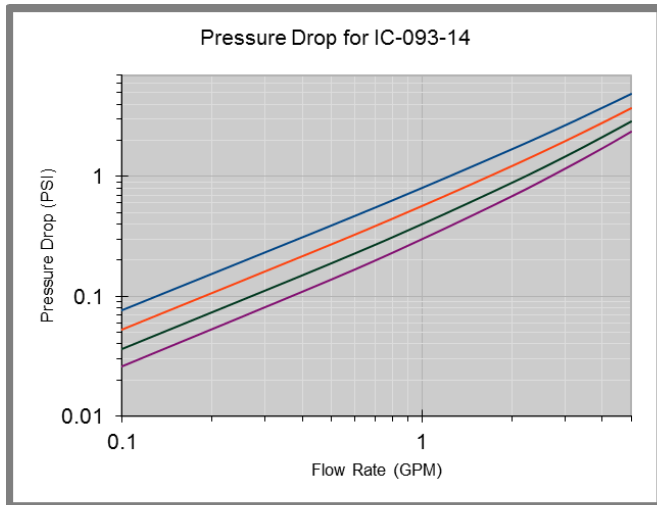

IC Series Cartridge

Hydraulic Properties: Low Conductivity Ethylene Glycol 40% (LC-EG 40%)

— 32°C (90°F) — 49°C (120°F) — 71°C (160°F) — 93°C (200°F)

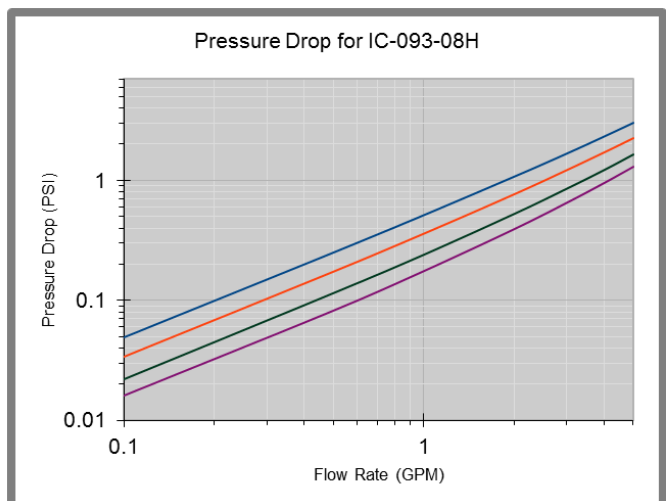
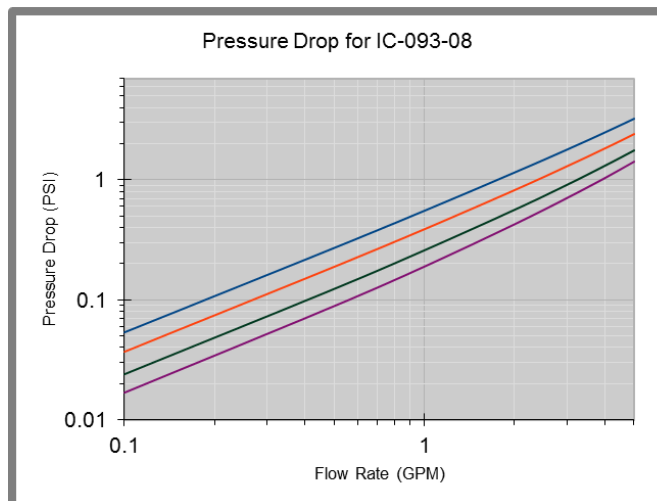
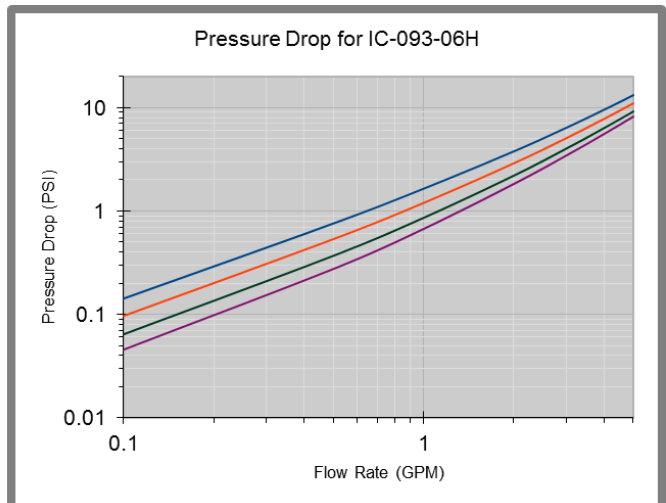
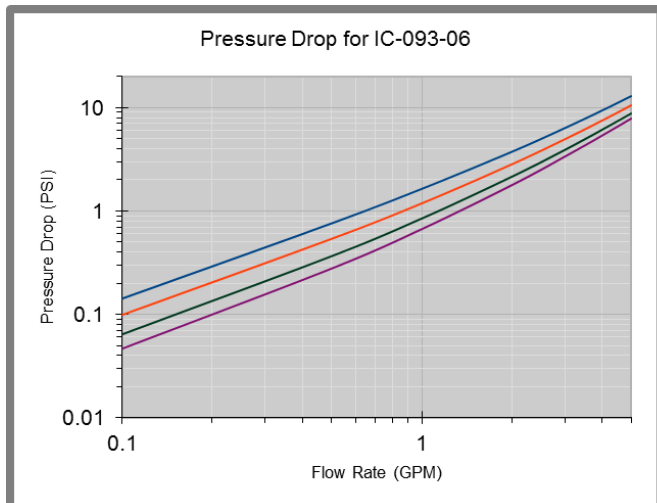
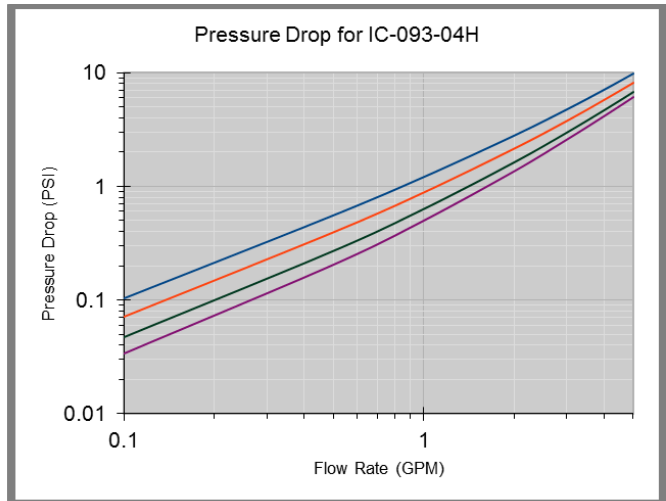
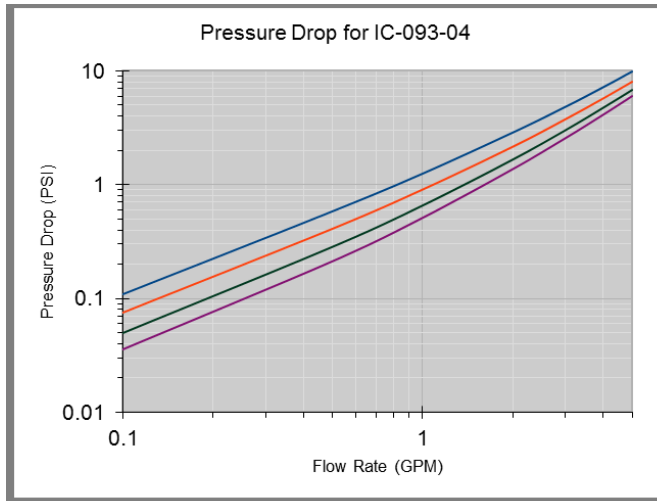

IC Series Cartridge

Hydraulic Properties: Low Conductivity Ethylene Glycol 40% (LC-EG 40%)

— 32°C (90°F) — 49°C (120°F) — 71°C (160°F) — 93°C (200°F)

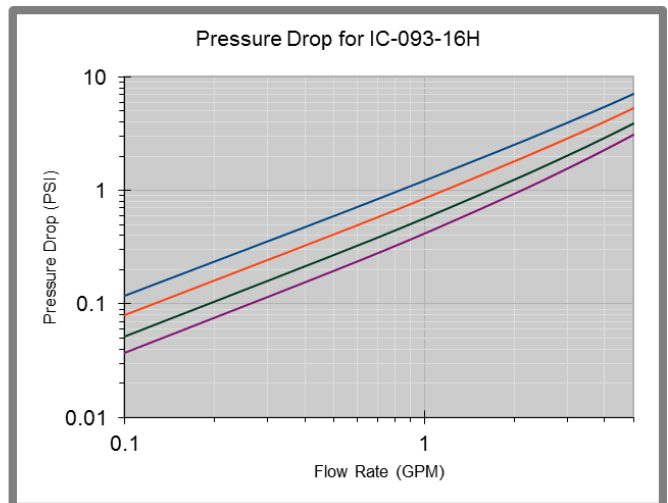
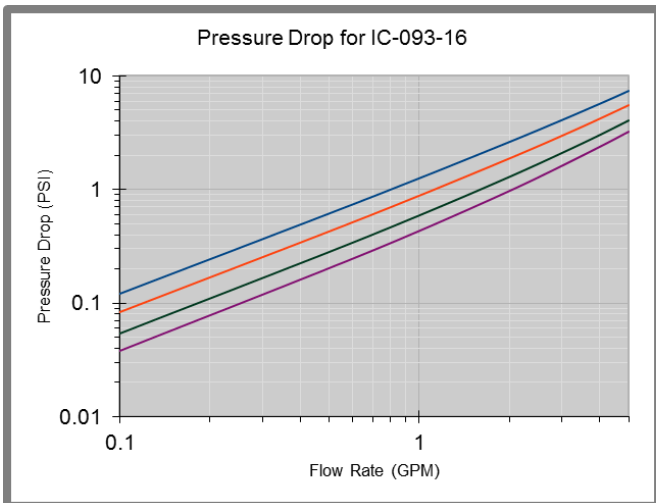
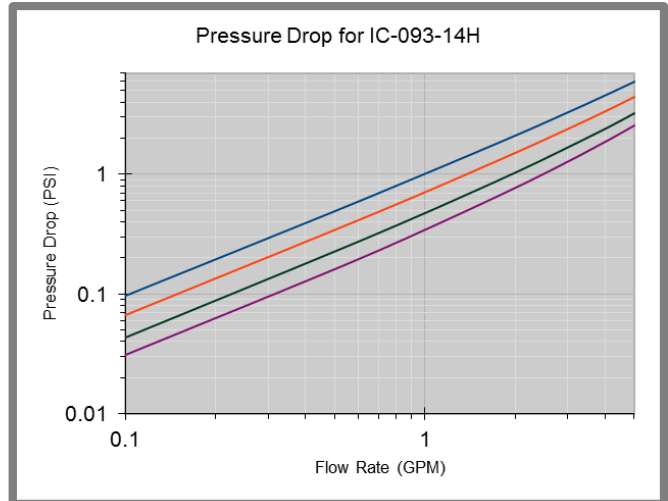
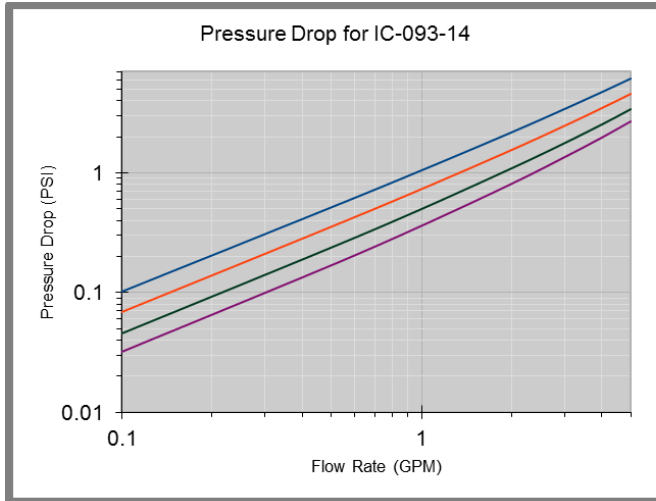

IC Series Cartridge

Hydraulic Properties: Low Conductivity Ethylene Glycol 50% (LC-EG 50%)

— 32°C (90°F) — 49°C (120°F) — 71°C (160°F) — 93°C (200°F)

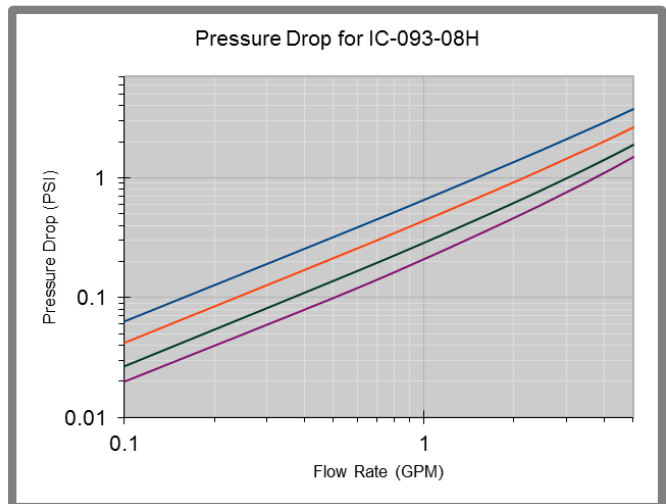
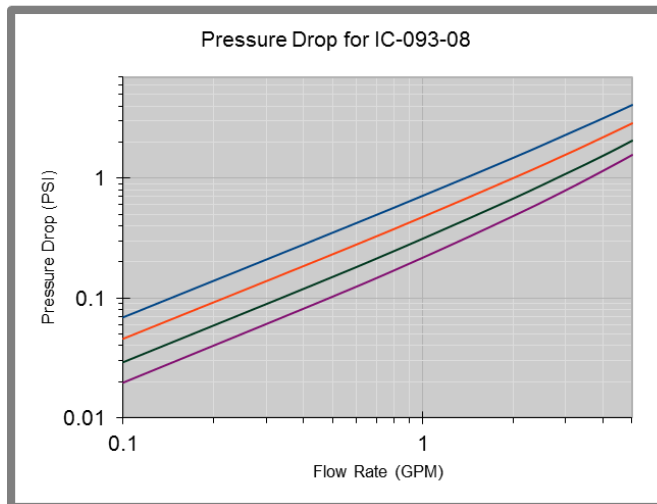
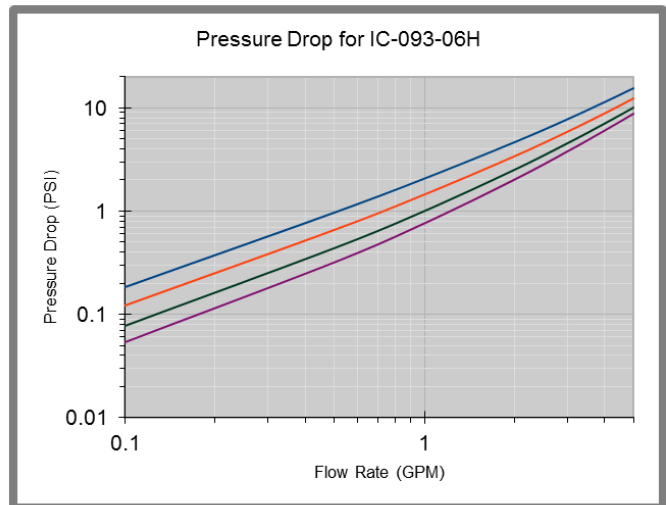
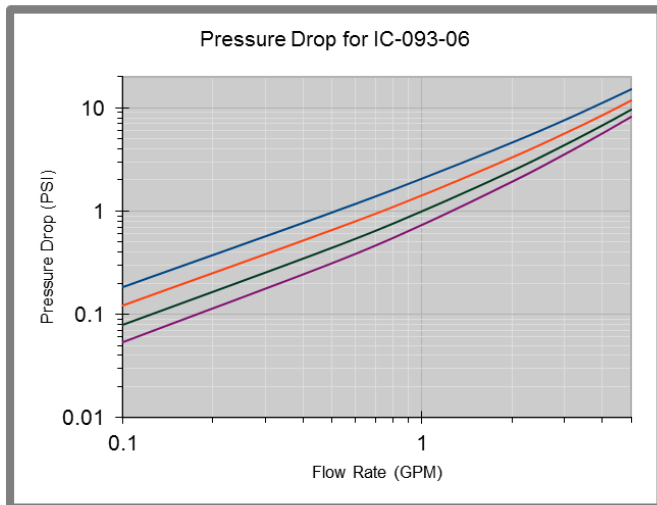
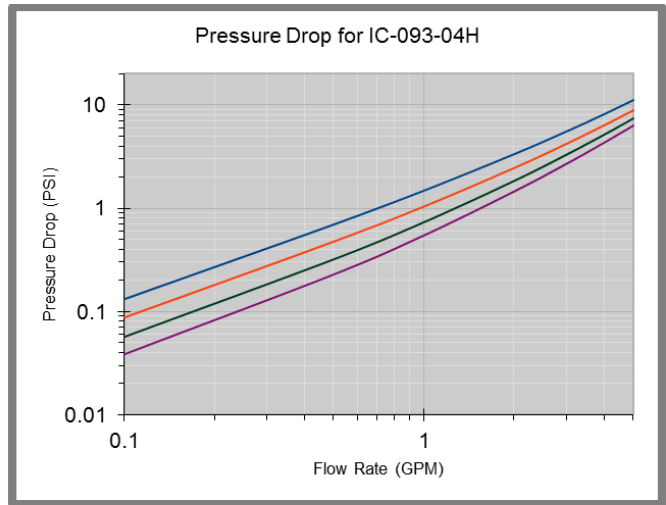
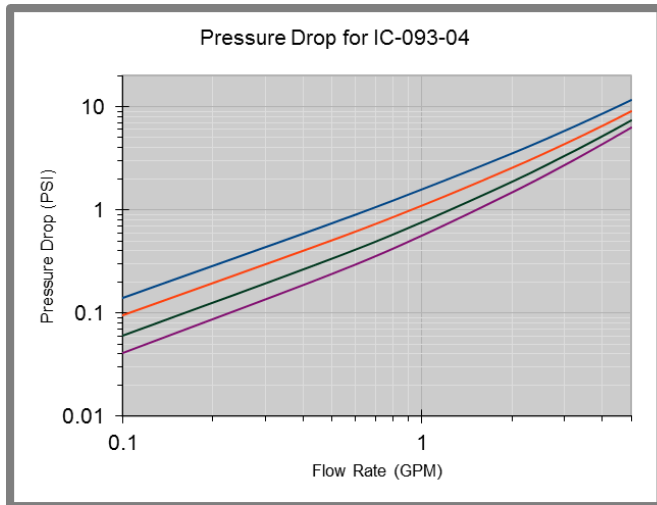

IC Series Cartridge

Hydraulic Properties: Low Conductivity Ethylene Glycol 50% (LC-EG 50%)

— 32°C (90°F) — 49°C (120°F) — 71°C (160°F) — 93°C (200°F)

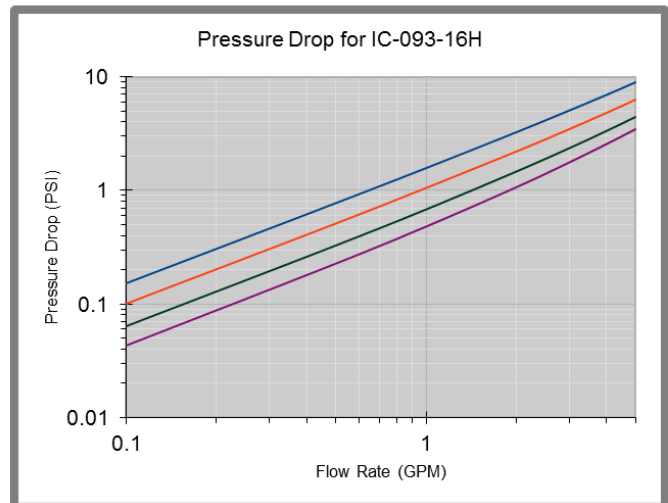
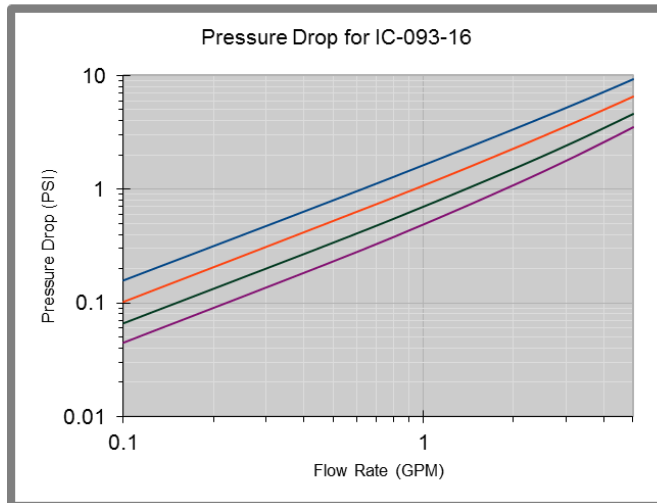
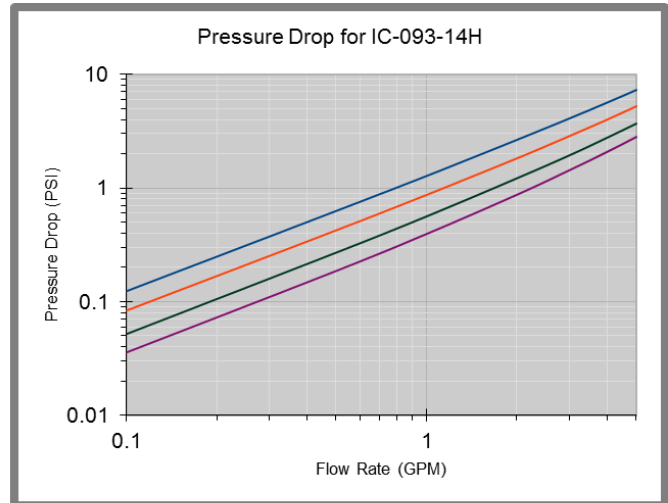
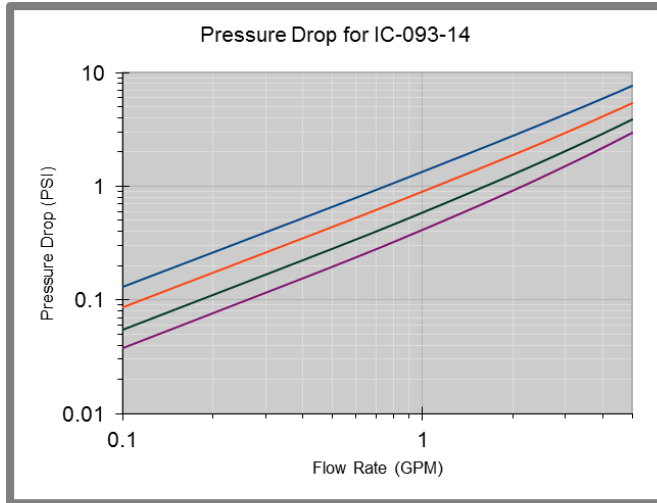

IC Series Cartridge

Hydraulic Properties: Low Conductivity Ethylene Glycol 60% (LC-EG 60%)

— 32°C (90°F) — 49°C (120°F) — 71°C (160°F) — 93°C (200°F)

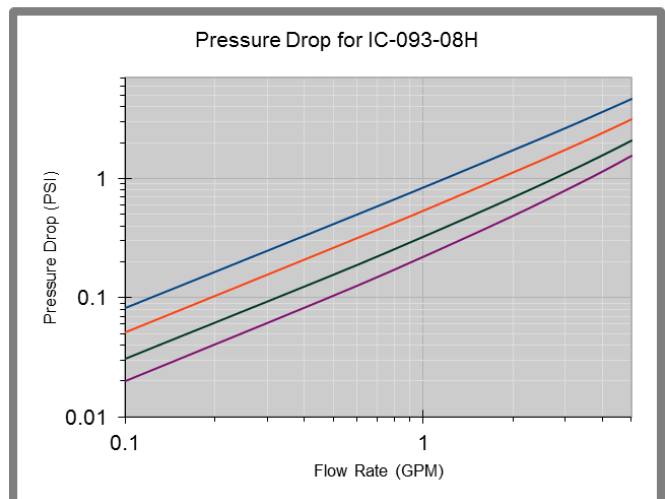
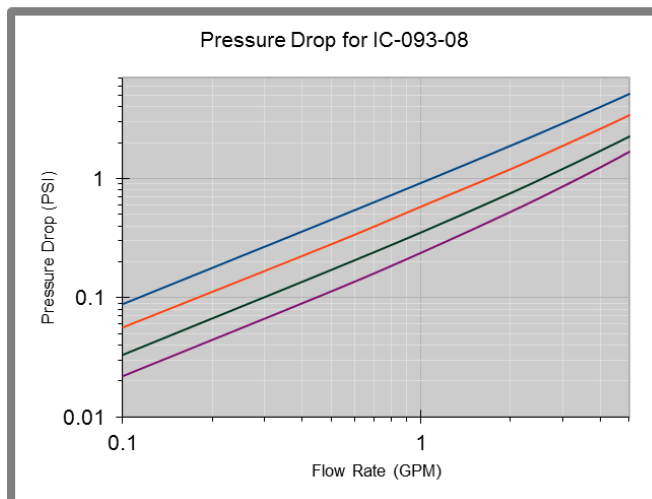
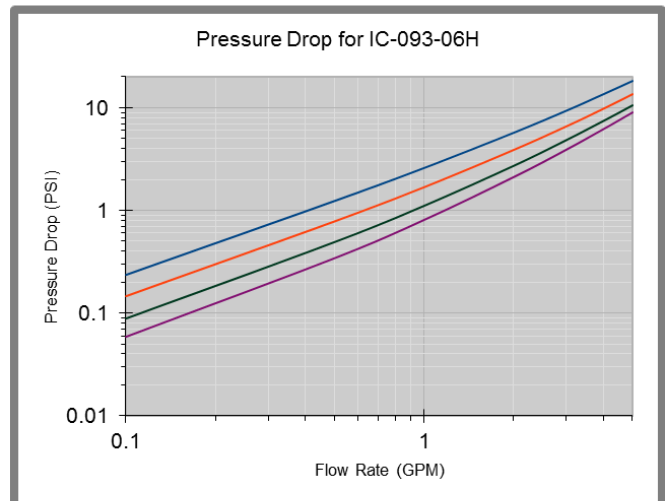
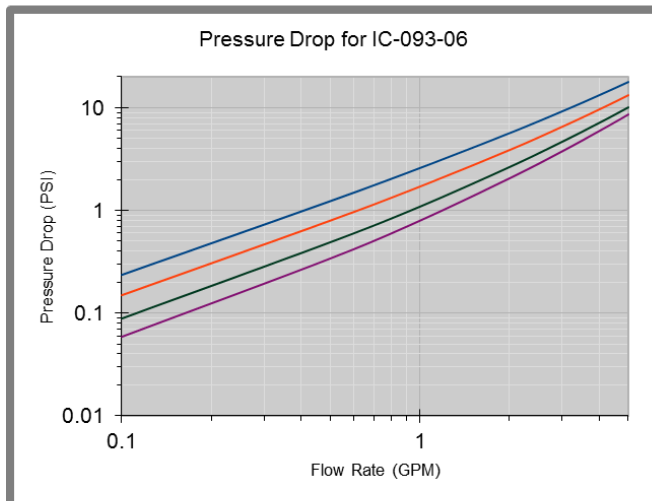
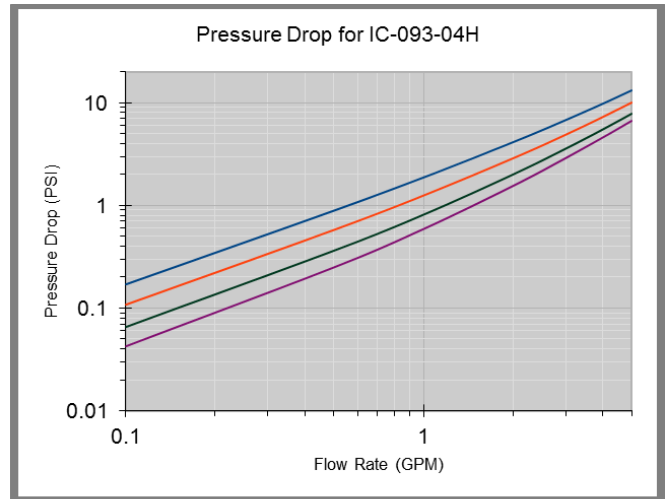
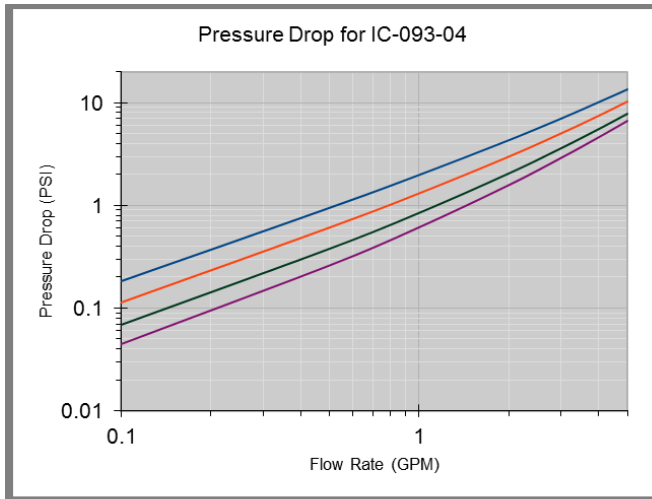

IC Series Cartridge

Hydraulic Properties: Low Conductivity Ethylene Glycol 60% (LC-EG 60%)

— 32°C (90°F) — 49°C (120°F) — 71°C (160°F) — 93°C (200°F)

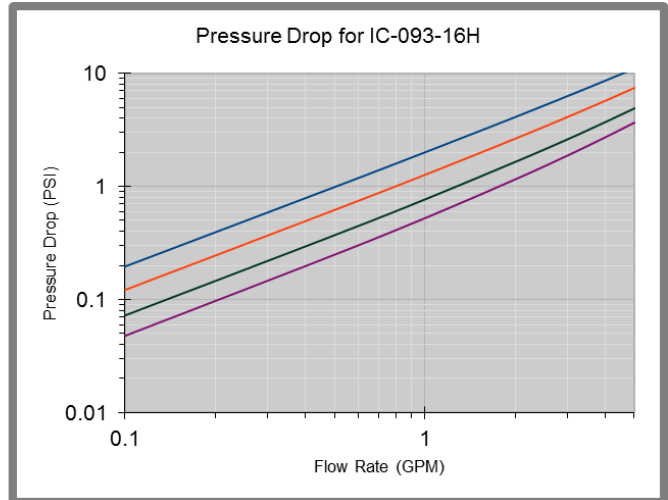
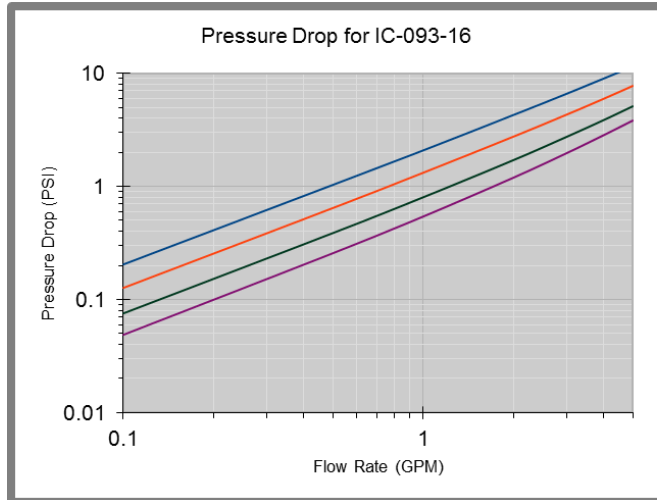
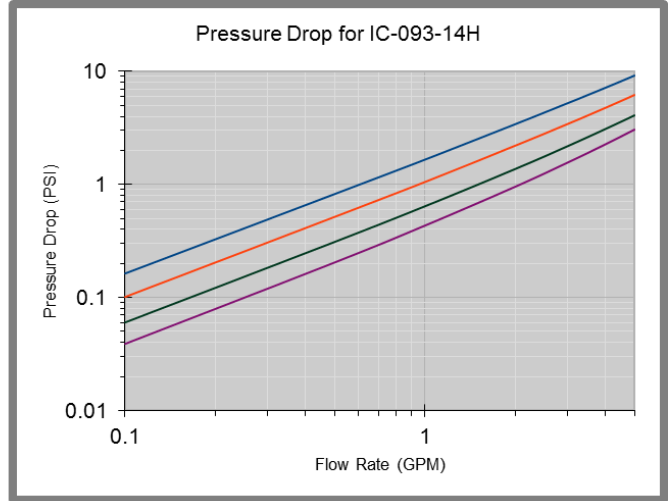
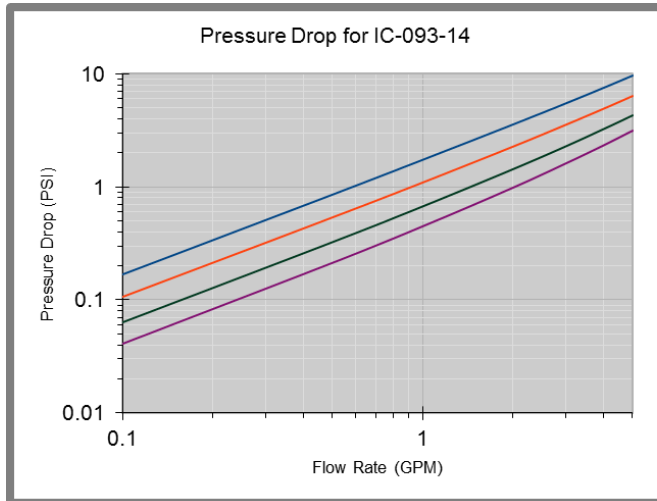

IC Series Cartridge

Hydraulic Properties: Low Conductivity Propylene Glycol 20% (LC-PG 20%)

— 32°C (90°F) — 49°C (120°F) — 71°C (160°F) — 93°C (200°F)

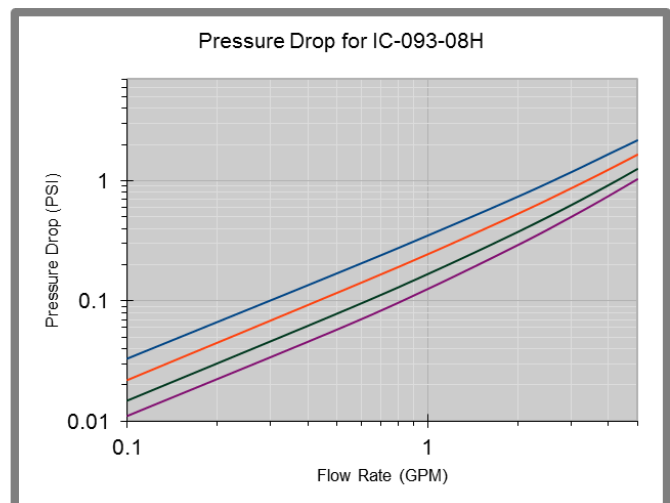
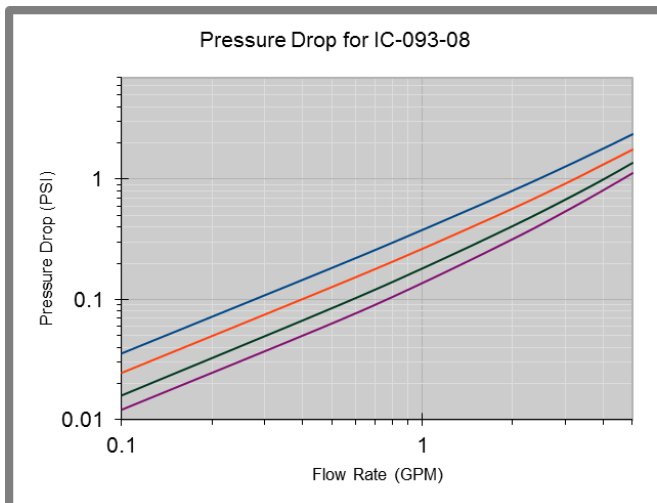
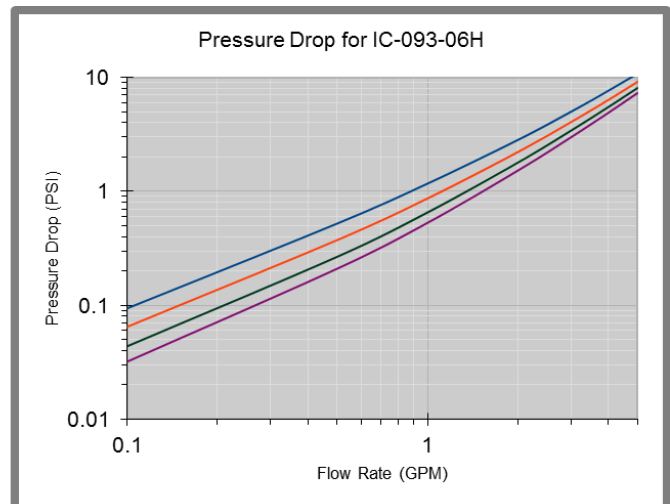
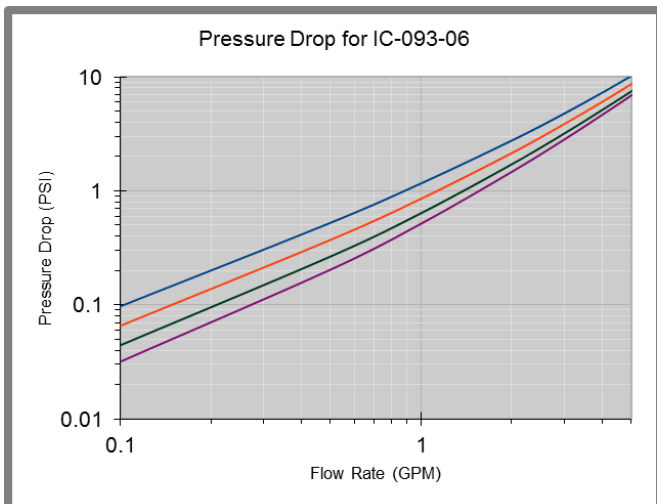
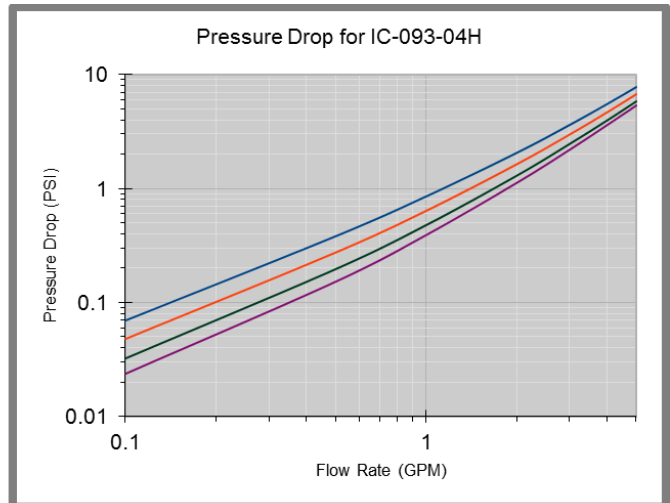
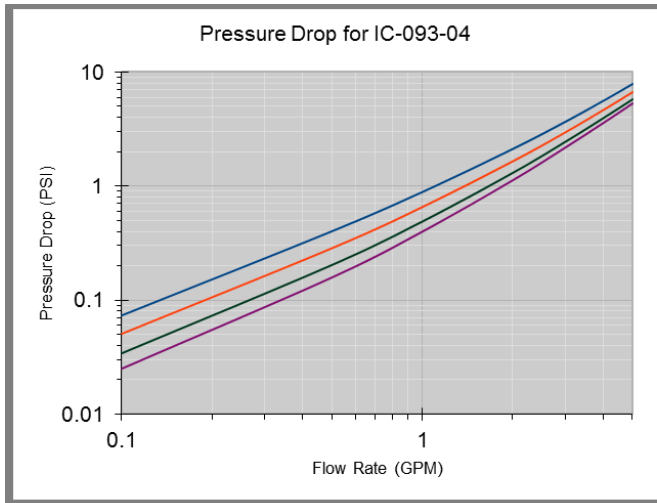

IC Series Cartridge

Hydraulic Properties: Low Conductivity Propylene Glycol 20% (LC-PG 20%)

— 32°C (90°F) — 49°C (120°F) — 71°C (160°F) — 93°C (200°F)

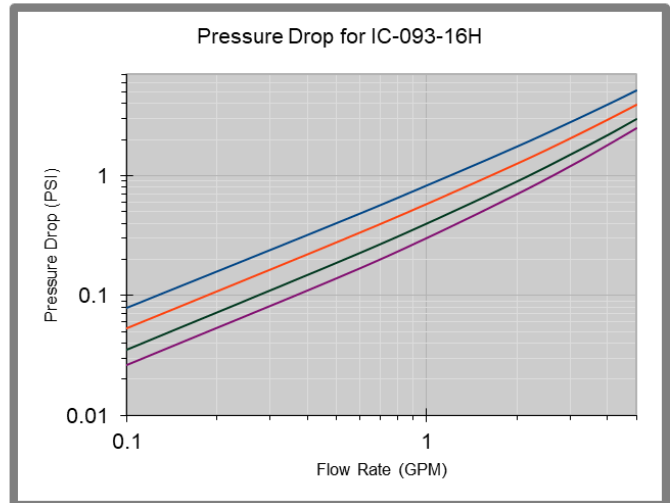
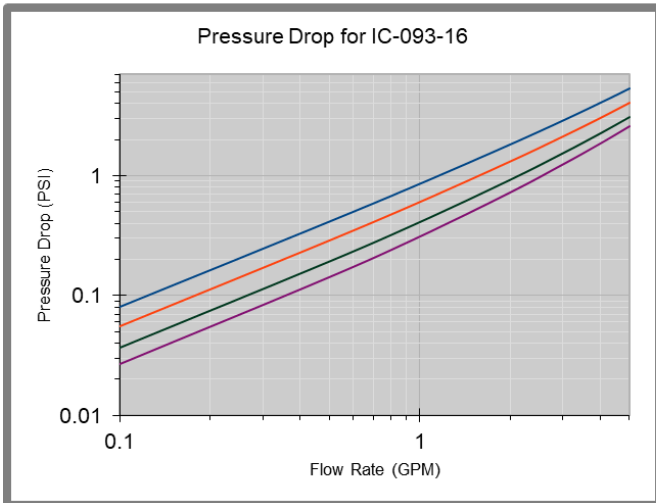
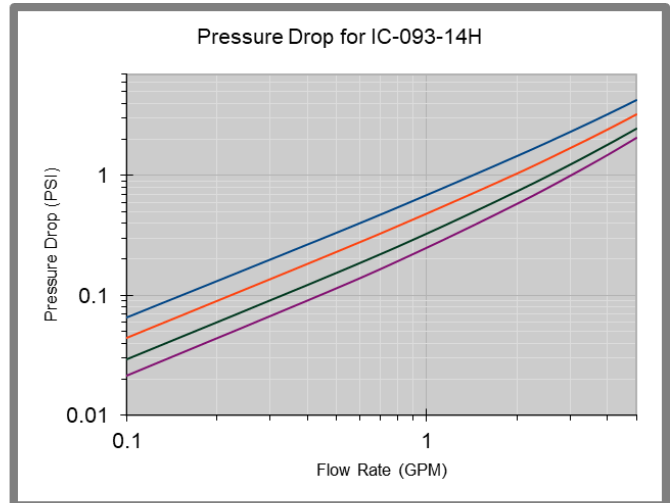
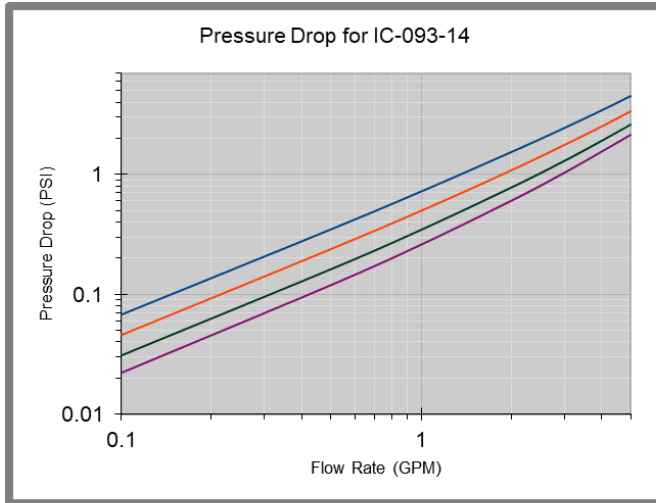

IC Series Cartridge

Hydraulic Properties: Low Conductivity Propylene Glycol 30% (LC-PG 30%)

— 32°C (90°F) — 49°C (120°F) — 71°C (160°F) — 93°C (200°F)

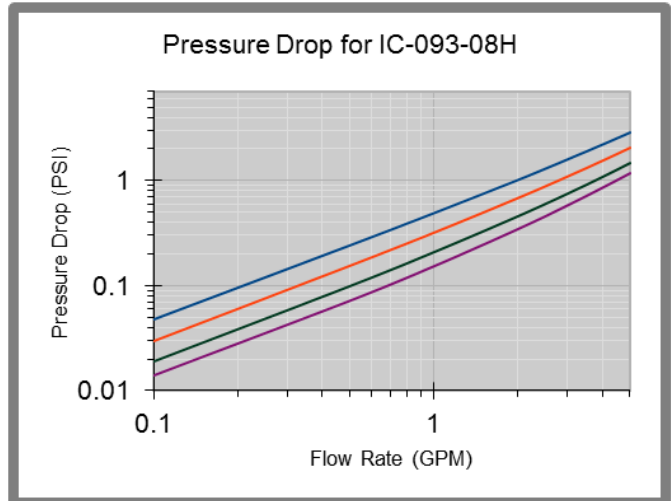
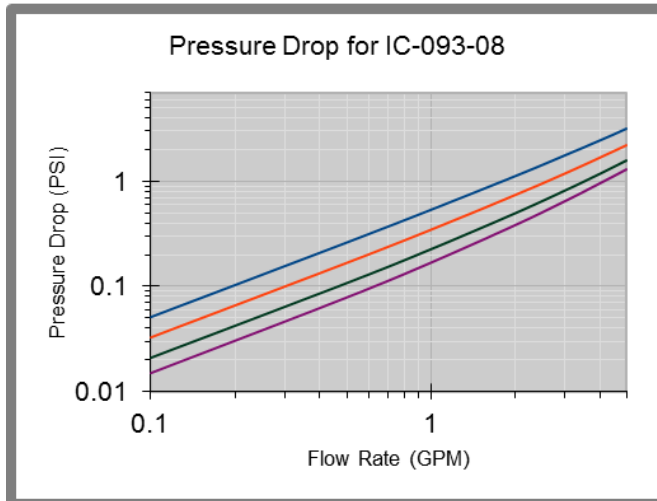
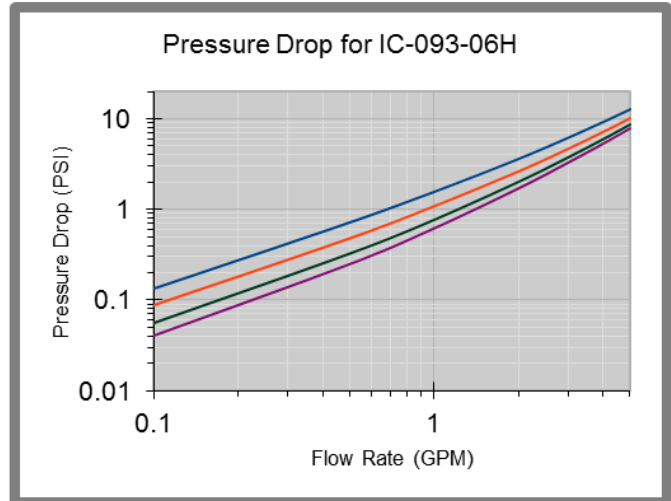
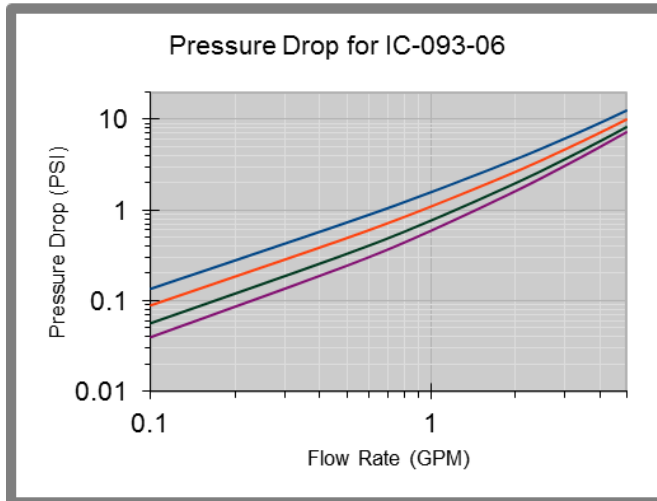
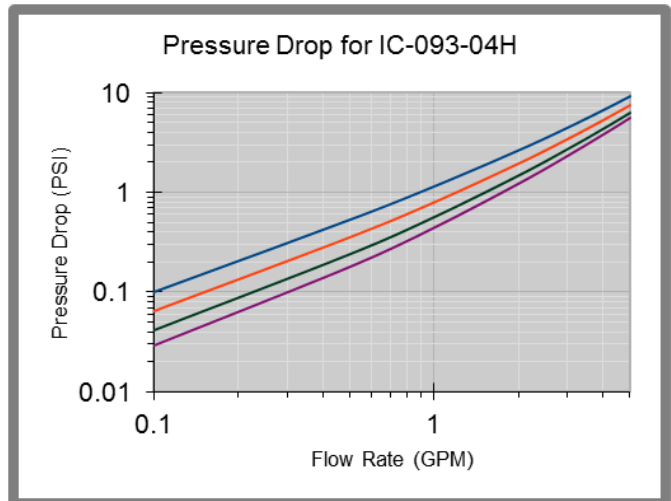
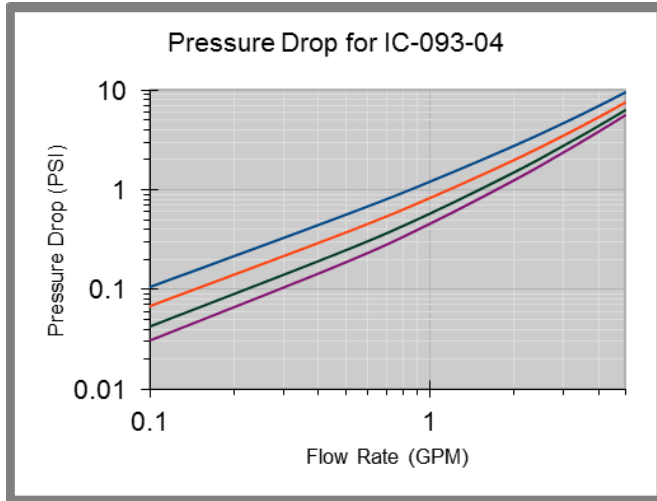

IC Series Cartridge

Hydraulic Properties: Low Conductivity Propylene Glycol 30% (LC-PG 30%)

— 32°C (90°F) — 49°C (120°F) — 71°C (160°F) — 93°C (200°F)

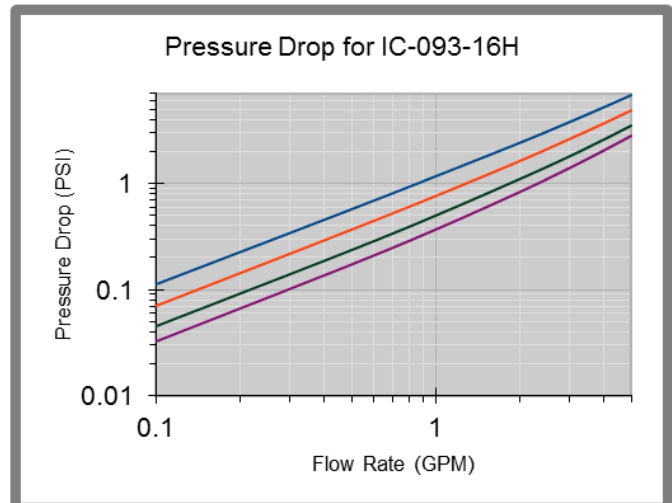
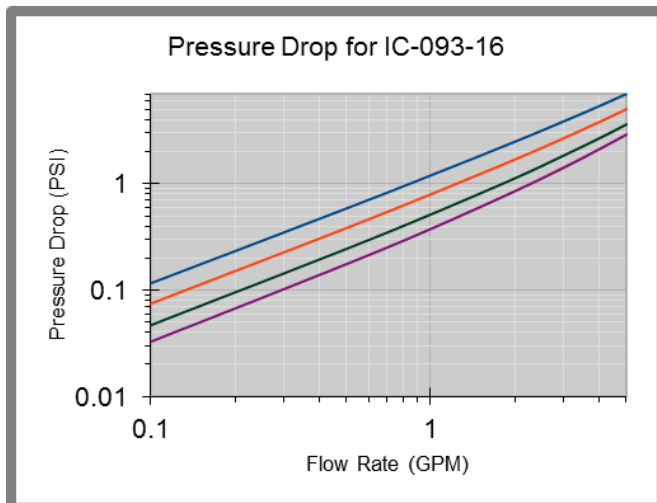
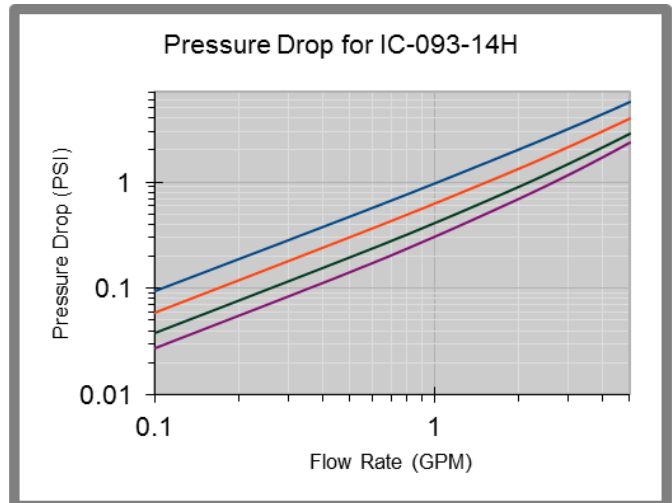
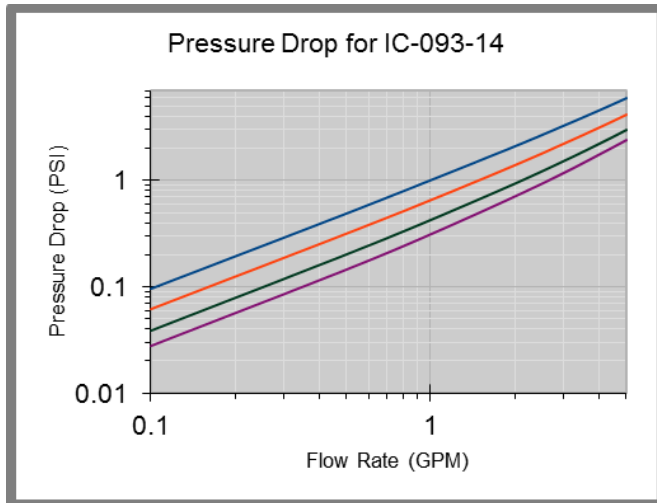

IC Series Cartridge

Hydraulic Properties: Low Conductivity Propylene Glycol 40% (LC-PG 40%)

— 32°C (90°F) — 49°C (120°F) — 71°C (160°F) — 93°C (200°F)

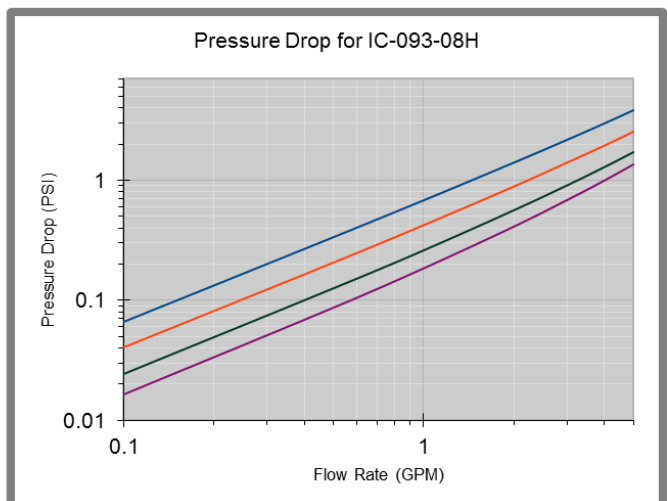
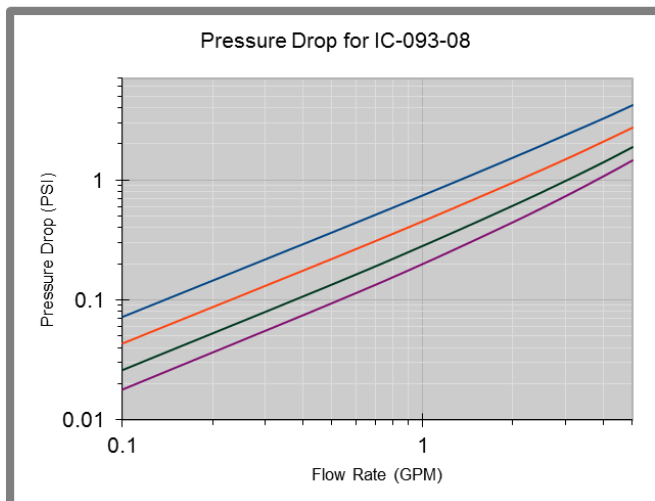
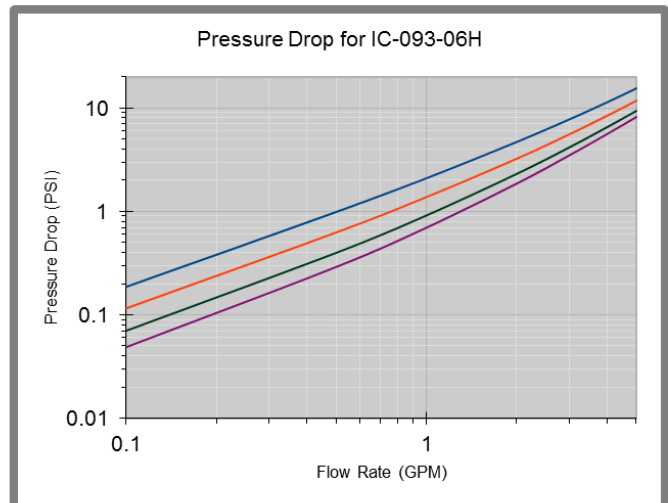
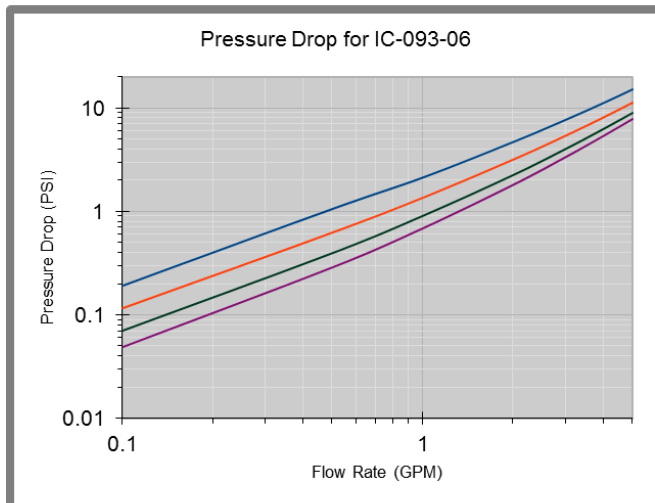
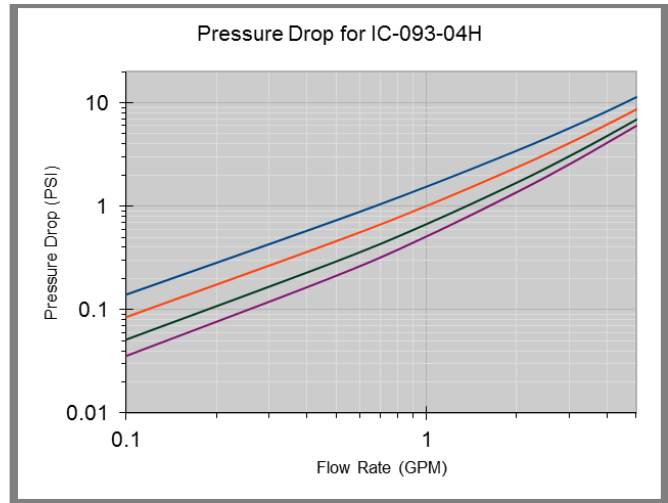
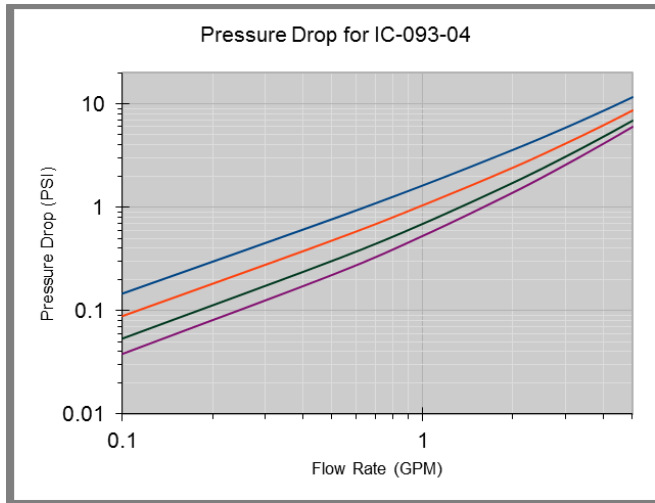

IC Series Cartridge

Hydraulic Properties: Low Conductivity Propylene Glycol 40% (LC-PG 40%)

— 32°C (90°F) — 49°C (120°F) — 71°C (160°F) — 93°C (200°F)

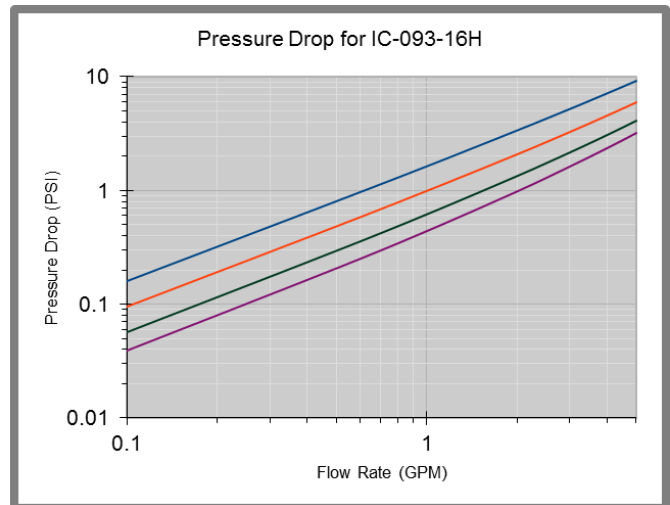
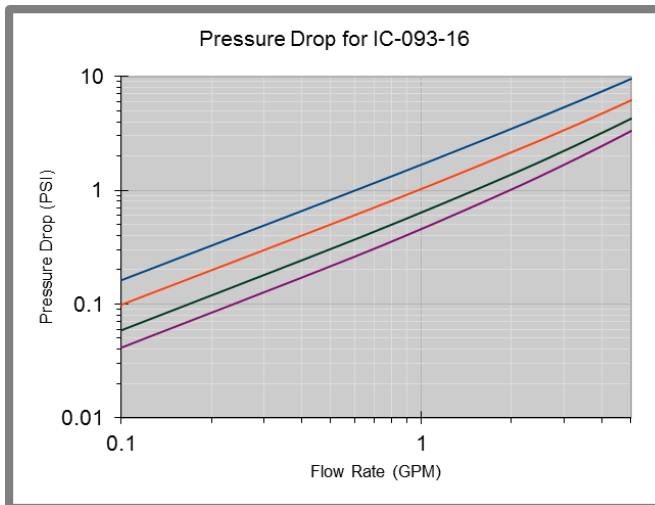
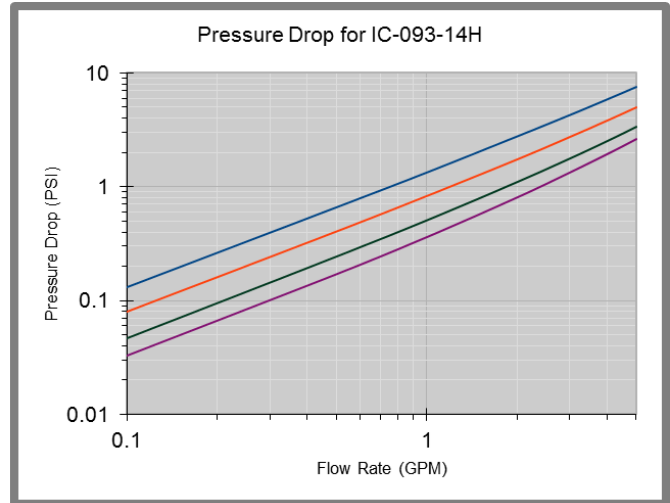
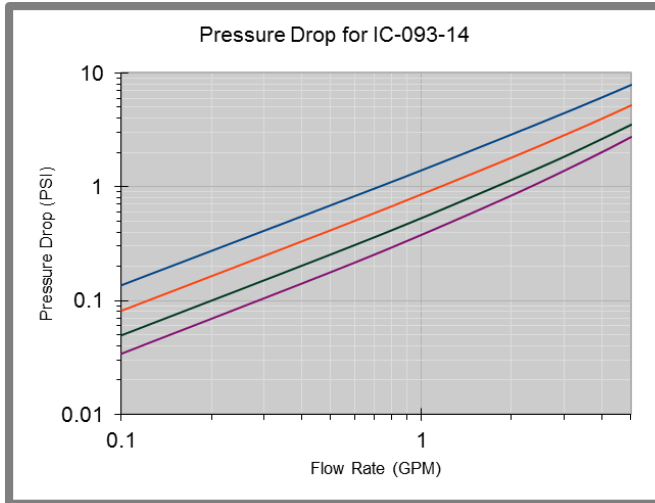

IC Series Cartridge

Hydraulic Properties: Low Conductivity Propylene Glycol 50% (LC-PG 50%)

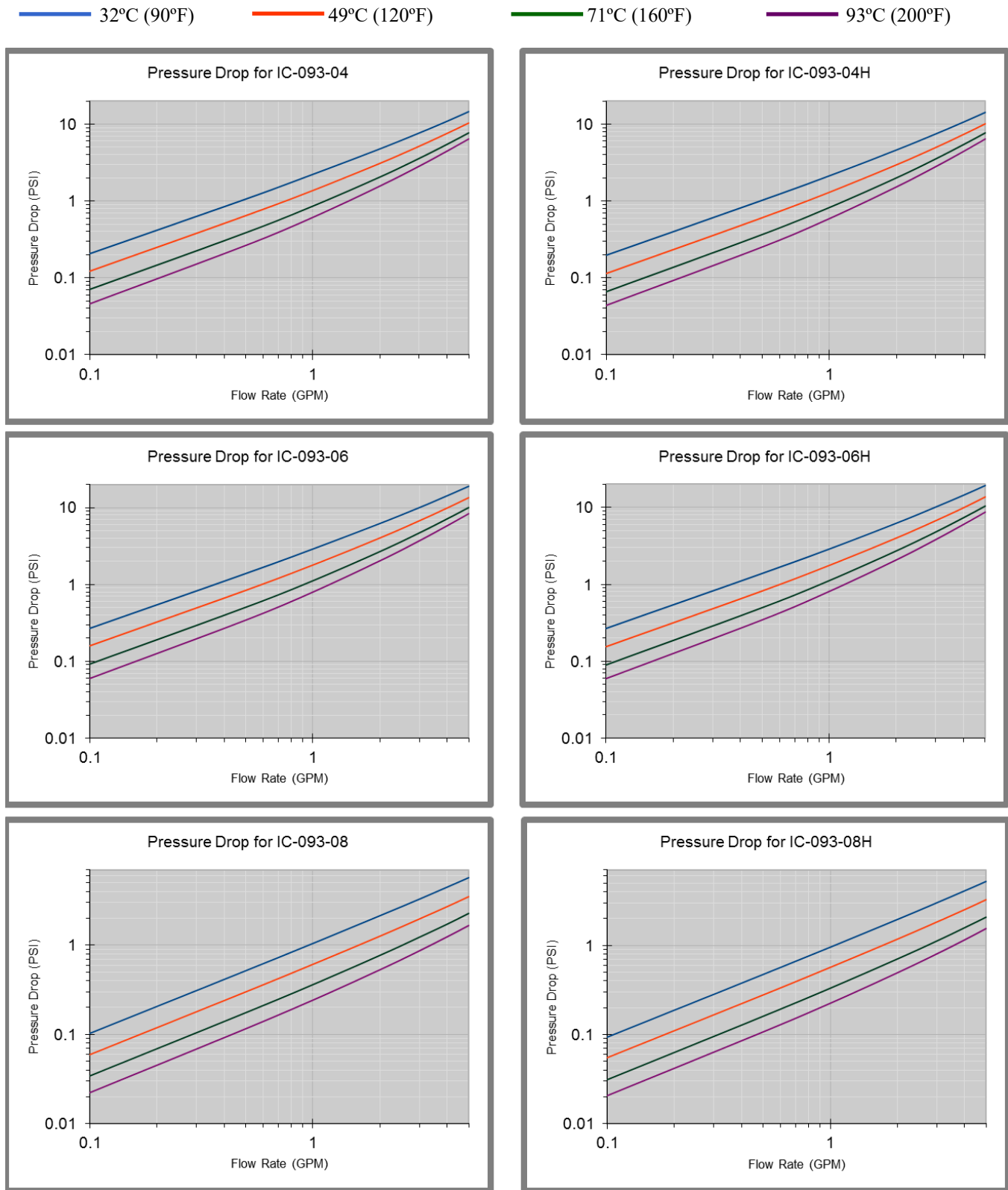

IC Series Cartridge

Hydraulic Properties: Low Conductivity Propylene Glycol 50% (LC-PG 50%)

— 32°C (90°F) — 49°C (120°F) — 71°C (160°F) — 93°C (200°F)

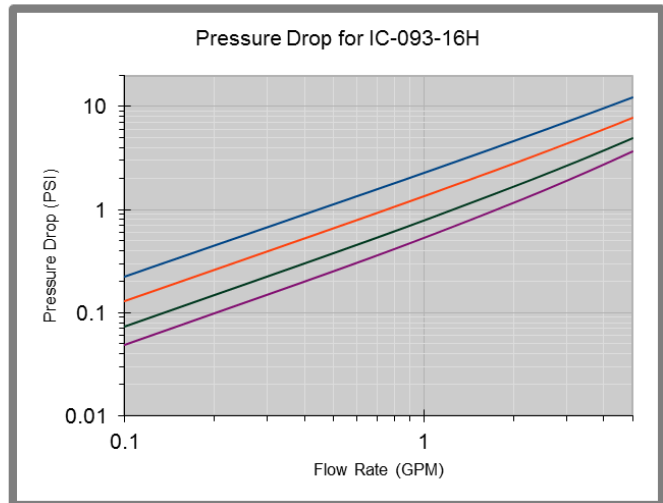
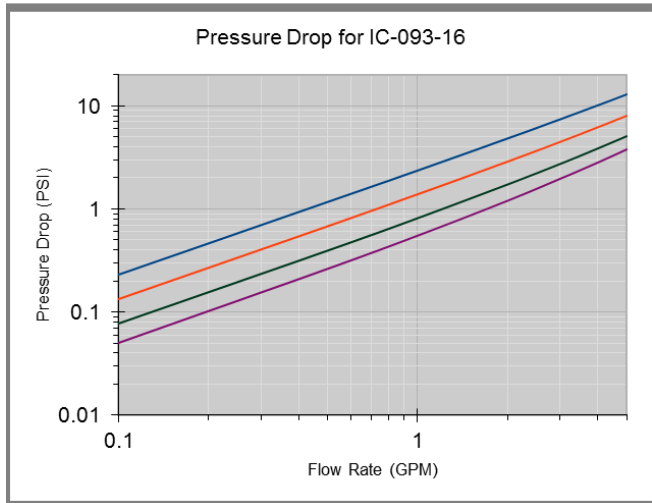
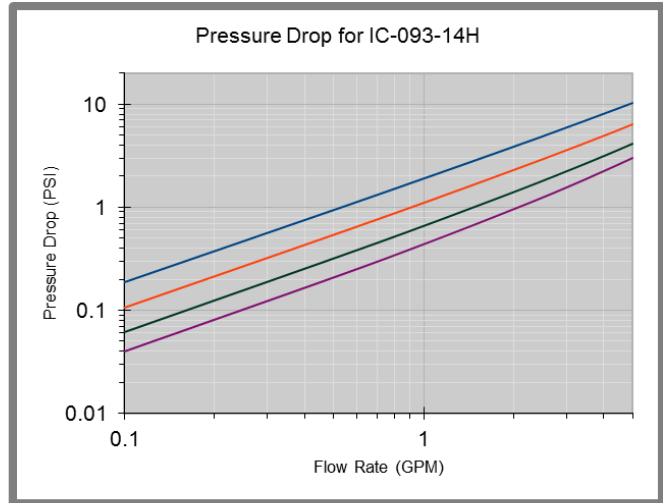
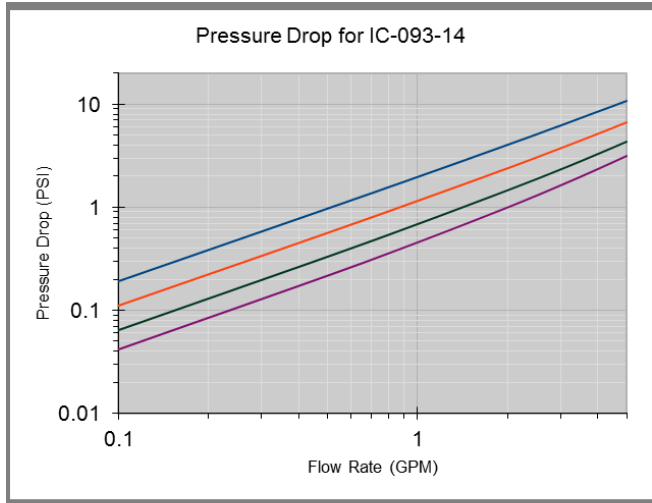

IC Series Cartridge

Hydraulic Properties: Low Conductivity Propylene Glycol 60% (LC-PG 60%)

— 32°C (90°F) — 49°C (120°F) — 71°C (160°F) — 93°C (200°F)

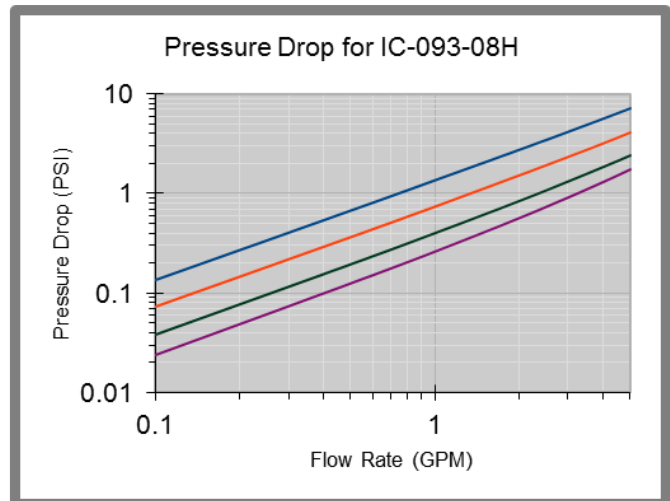
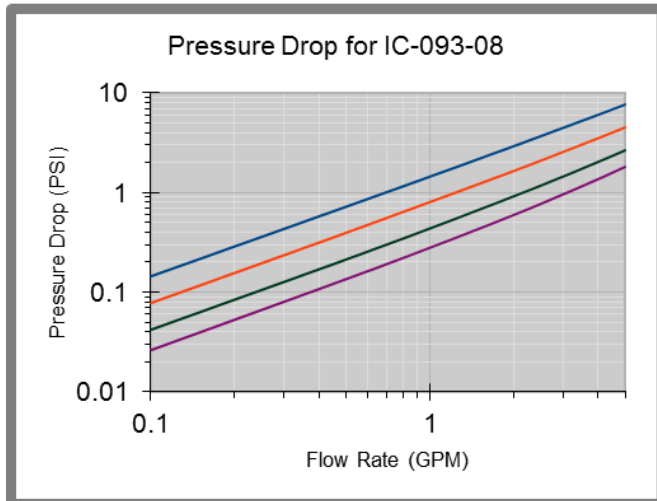
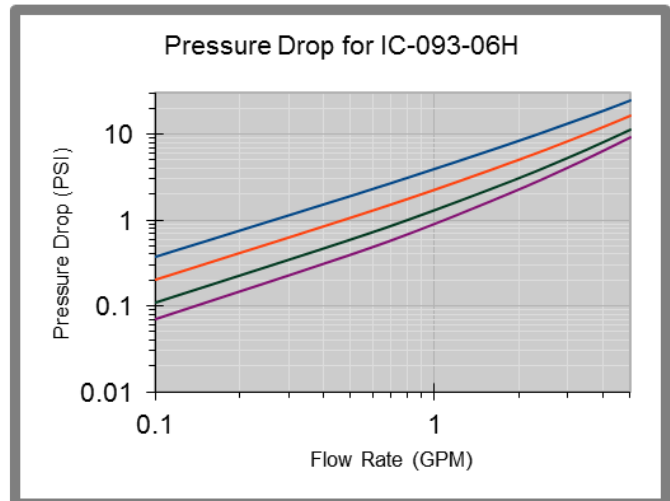
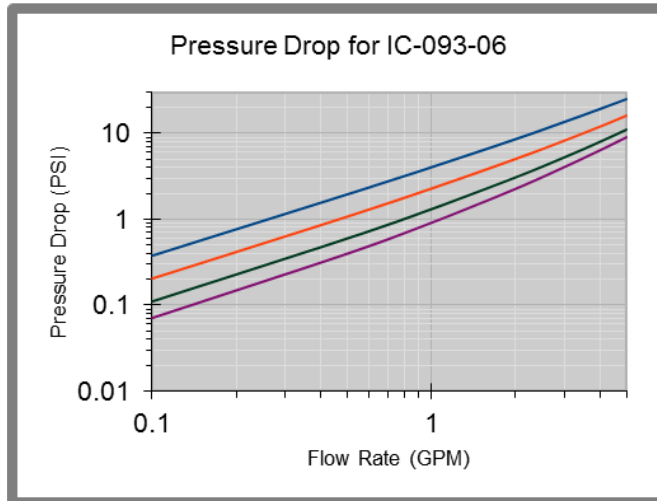
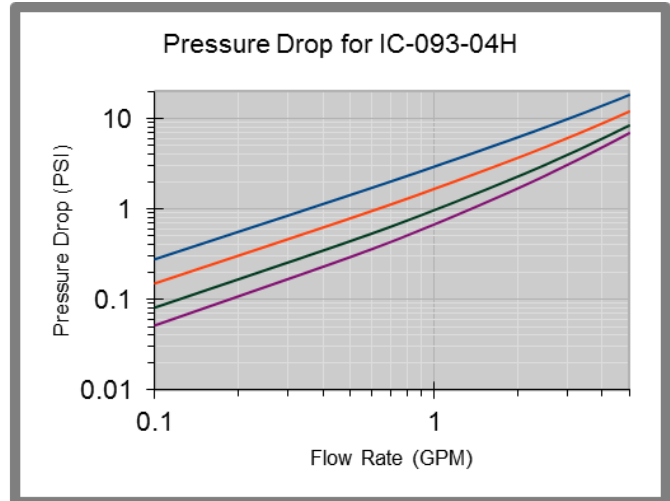
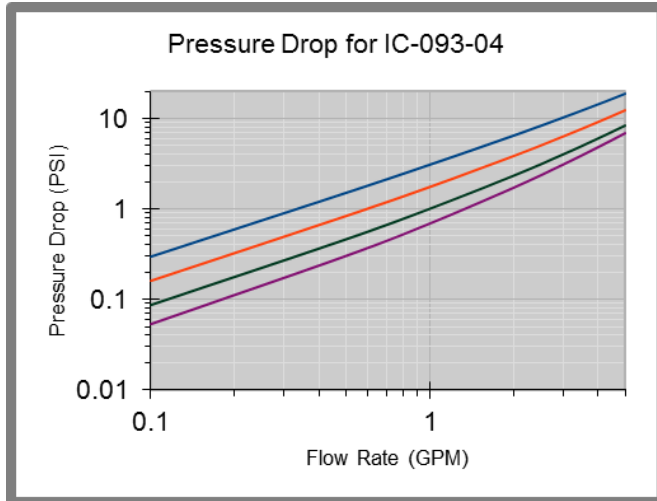

IC Series Cartridge

Hydraulic Properties: Low Conductivity Propylene Glycol 60% (LC-PG 60%)

— 32°C (90°F) — 49°C (120°F) — 71°C (160°F) — 93°C (200°F)

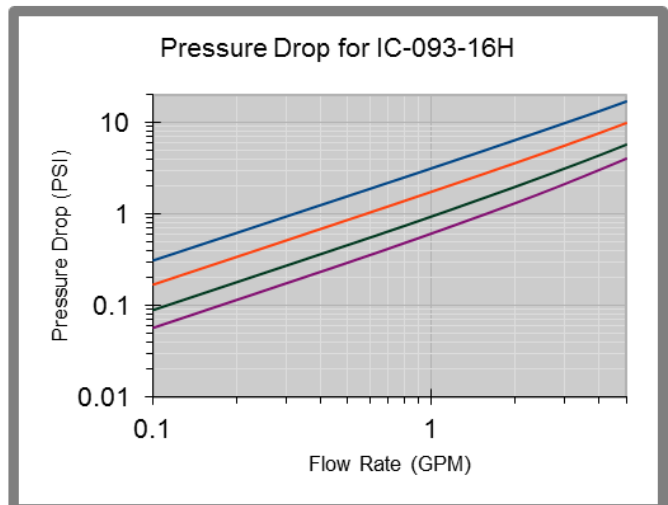
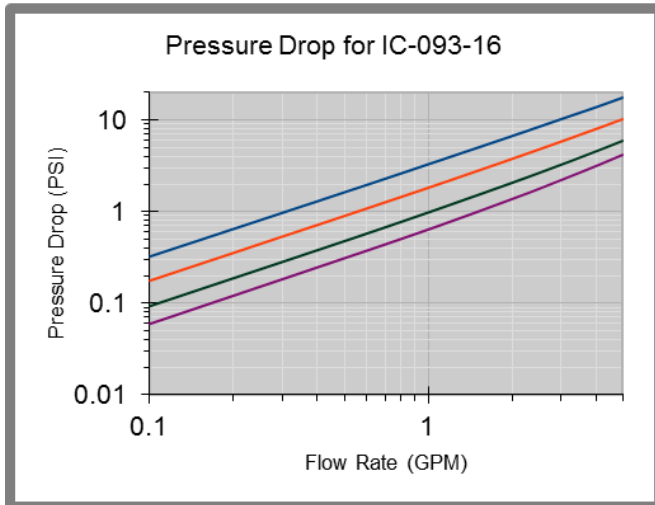
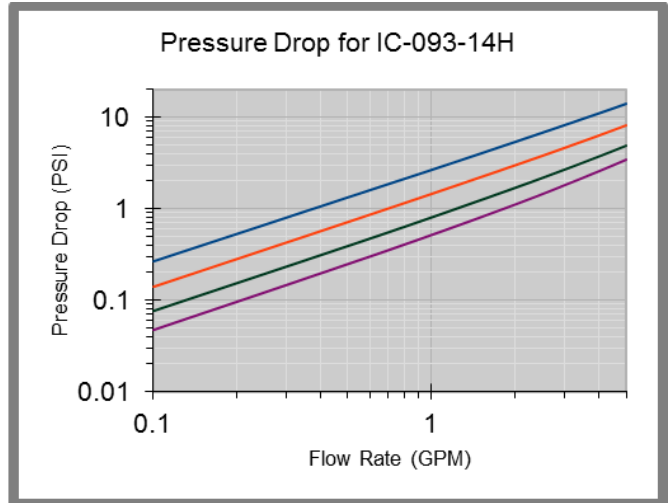
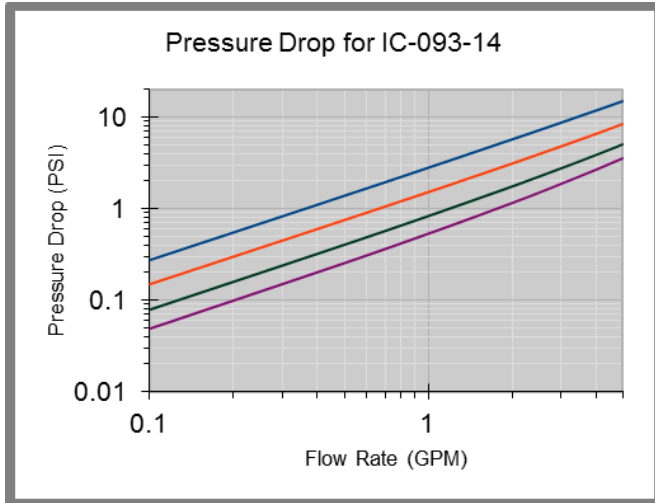

Series Overview

CR Series is a contamination removal solution offered by Dynalene to remove several contaminants present in water and water based liquids. Dynalene offers products in the form of cartridges for low flow rates, as well as, custom designed systems for higher flow rates. Some of the contaminants that can be removed using the CX series cartridges are: chloride, molybdate, vanadium, nickel, lead, selenium, etc.

Cartridge Products:

CR Series cartridges are easy to install in systems which operate up to 200°F. These cartridges have low pressure drop and can operate at pressures up to 40 Psi. The cartridges are available in standard sizes (4, 6, 8, 14, and 16 inches). The length and diameter of these cartridges can be customized to meet any customer's need. The cartridges are designed and tested for different operating conditions to ensure the product's quality and performance.



Features:

- Wide range operational temperature
- High capacity media
- Performance tested for a long operating cycle
- Compatible with water and water based chemistries including glycol based heat transfer fluid
- Resistant to physical and chemical deterioration
- Easy to install
- Easy to custom design

Specifications

Properties	Value
Max. operating temperature	194°F (90°C)
Material of construction	Polypropylene (Customization available– Including Nylon, ABS, stainless steel, etc.)
Max. operating pressure	30 PSI
Max. flow rate	0.3 to 2.5GPM - Customization available

Large Scale Contamination Removal:

Dynalene can custom design systems for large scale contamination removal applications. Dynalene's Contamination Removal System (CRS) can be designed to accommodate flow rates up to 250 gallons per minute. Some features of the CRS are:

1. Pressure Vessels: Pressure vessels can be made available in fiber glass, stainless steel or carbon steel construction. These pressure vessels can be made available in code or non-code versions up to 250 psig working pressure. The vessels are epoxy lined to protect from corrosion.
2. Flow Rate: The CRS can be custom designed to accommodate flow rates for 5 GPM to 250 GPM.
3. External piping design: The system can be pre-piped using Schedule 80 PVC, carbon steel or stainless pipes. The whole system is pressure tested before shipping to the job site.



4. System control package: The CRS can also be offered with a pre-installed Microprocessor/Digital display controller with a flow control assembly which enables automatic operation of the CRS for continuous and effective contamination removal operation.

5. Mounting: The CRS can be Pallet mounted or floor mounted. The pallet mounted CRS can be moved using a forklift.

Specifications

Properties	Value
Material of construction	Fiber glass, carbon steel and stainless steel
Max. operating pressure	Available up to 250 psig
Flow rate capability	5 to 250 GPM
Code Stamp availability	The vessels can be made available both in codes or non-code versions
Media	Ion exchange resin or Activated carbon

Applications

- Waste water treatment
- Residential water treatment
- Laboratory water treatment
- Glycol regeneration

Along with the standard products, we can also custom design cartridges and large contamination removal system that can meet your requirements. Contact us today at [610.262.9686](tel:610.262.9686) or email at info@dynalene.com and discuss your application with Dynalene's cartridge experts today.

General Information

Arsenic Removal (CR-AS):

Maintaining low concentrations of metalloids such as arsenic is very important due to strict environmental regulations for wastewater effluents. Arsenic is one of the most toxic elements which is lethal for both humans and animals. The maximum allowable arsenic concentration in the wastewater effluents is 0.104 mg/L. Arsenic compounds are used in different industries such as copper, lead, zinc, glass, semiconductor, and wood preservative materials. Contact with inorganic arsenic may cause severe health issues including death, growth inhibition, and behavioral effects. Dynalene's arsenic removal system can be used for wastewater, and is able to reduce arsenic concentration below 0.104 mg/L.

Chloride Removal (CR-CL):

Dynalene's chloride products can be used for water and heat transfer fluids such as ethylene glycol, propylene glycol, and triethylene glycol. It is able to reduce chloride concentration from more than 2500 ppm to below 25 ppm. High chloride concentration in heat transfer fluids can cause corrosion, system clogging with salts, reduction in heat transfer efficiency, and can sometimes lead to system shutdowns. Public drinking water standards require chloride levels not to exceed 250 mg/L.

Color and Odor Removal (CR-CO):

Water's color or odor does not necessarily reflect whether it's drinkable. However, clear water is a reassuring sign to most people living in industrialized nations and, in some cases, color in the water can indicate unsafe levels of contaminants. More stringent and rigid standards of quality in regards to color of waste water is due to its effect towards photosynthetic

activity of the aquatic plants. Color and odor generation in glycol may occur due to an increase in contamination or due to degradation of the heat transfer fluids.

Dynalene can offer products that can be used for color and odor removal in water and heat transfer fluids such as ethylene glycol, propylene glycol, and triethylene glycol.

Lead Removal (CR-PB):

Small amounts of lead cause serious health problems. Lead poisoning can severely affect mental and physical development of children younger than 6 years and lead at high levels can be fatal. Lead contamination in drinking water is mostly found through corrosion of pipes connecting homes to the water main. The EPA has set a lead action level of 15 µg/L in which 10 percent of tap water samples cannot exceed that level, otherwise action must be taken. The maximum contamination limit (MCL) set for lead is zero due to it being toxic, especially to young children. Dynalene's lead removal system can be used for wastewater, and is able to reduce lead concentration below 7 µg/L.

Molybdate Removal (CR-MO):

With stringent regulation of the allowable molybdate levels in wastewater discharged to the drain, companies can be penalized by water authorities for failing to meet the wastewater requirement. The maximum allowable molybdenum concentration in the wastewater effluents is 0.04 mg/L. Molybdenum is a valuable alloying agent, its concentration has a large impact on the alloy's toughness and hardenability. Molybdenum is necessary for all the species; however, its dosage should be tiny. The high concentrations of molybdenum can be toxic. Dynalene's molybdenum removal products can be used for wastewater, and is able to reduce molybdenum concentration below 0.04 mg/L.

Nickel Removal (CR-NI):

Due to the adverse effect caused by nickel in the ecosystem, there has been stringent environmental regulation to keep its concentration lower than 0.4mg/L in wastewater streams. Nickel is popularly used in plating iron and brass, coating chemistry equipment, and manufacturing certain alloys that retain a high silvery polish, such as German silver. Nickel is also used as an additive for metals in the steel industry. Nickel like all heavy metals can enter the ecosystem and affect microorganisms and animals. High nickel concentrations in sandy soil and groundwater can damage plants and diminish the growth rate of algae. When the maximum tolerable amount is exceeded nickel may cause cancer. Dynalene's nickel removal system can be used for wastewater, and is able to reduce nickel concentration below 0.4 mg/L.

Selenium Removal (CR-SE):

Selenium is widely used in electronics due to its impressive photovoltaic and photoconductive properties. It is also used in the glass and animal food industries. Selenium has emerged as a contaminant of concern in water treatment facilities in industries such as mining, oil refining, and power generation. With increased enforcement of selenium regulations and increased understanding of the health and environmental effects it causes, the need to efficiently remove selenium has increased. Elemental selenium is relatively nontoxic; however, it has been reported that 0.01 mg/L of selenium ion can cause physical deformities and reproductive failure in aquatic species. Dynalene can offer products that can lower selenium concentrations in water to below this level of concern.

Sulfate Removal (CR-SO):

Sulfate most commonly enters water sources naturally through dissolving sulfate minerals. Sulfate is a secondary contaminant with a max contamination level (MCL) of 250 mg/L. Sulfate contamination most commonly affects the color and taste of water, while high concentrations of sulfate can be corrosive to the equipment and pipping of a system. Controlling sulfate concentration in a system can help prevent corrosion, which will reduce shutdowns due to servicing or maintenance, reduce crystal build-up in pipping which reduces flow, and can help prevent leaks through deterioration of pipping. Dynalene's sulfate removal system is able to reduce the concentration of sulfate well below the MCL.

Vanadium Removal (CR-VA):

Maintaining low concentrations of heavy metals such as vanadium is very important due to strict environmental regulations for wastewater effluents. The maximum allowable vanadium concentration in the wastewater effluents is 0.0662 mg/L. Vanadium which is used as an additive for metals in the steel industry can enter into the ecosystem and affect microorganisms and animals. Vanadium causes inhibition of certain enzymes in animals which has certain neurological effects. Additionally, vanadium has negative effects on the liver and kidneys. Dynalene's vanadium removal system can be used for wastewater, and is able to reduce vanadium concentration below 0.0662 mg/L.

Other Contaminants:

Dynalene can also offer systems to remove other contaminants, such as calcium, magnesium and phosphate, in both water and glycol based fluids. Due to our laboratory capabilities and our extensive experience with fluids, we can test samples to determine the amount of contaminants and the effect that they may have on the environment or engineering equipment.

CR Series

Cartridge Product Selection Guide and Order Information

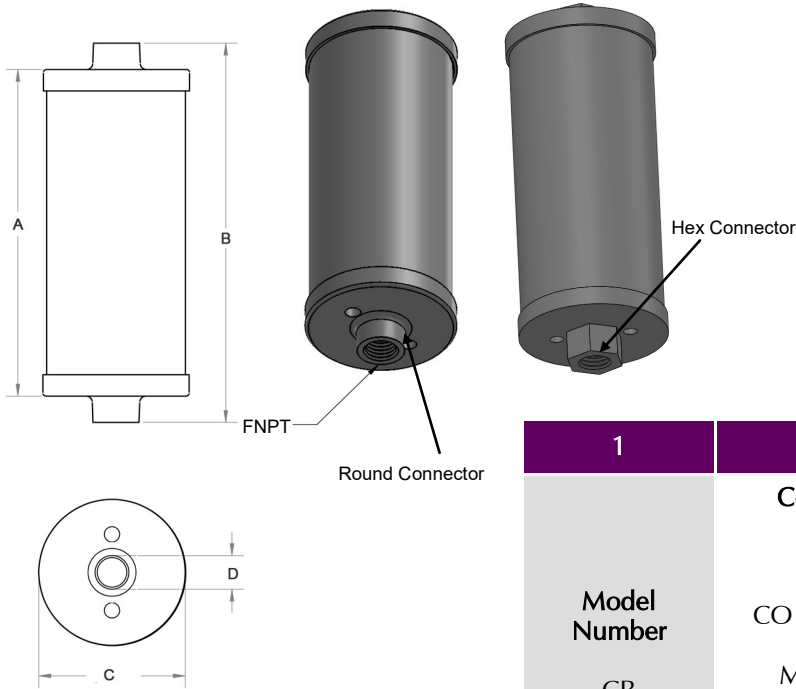

Material of Construction	Polypropylene
Maximum Pressure	40 psi
Orientation	Vertical

Model Number	Contaminant	Length	Connector
1	2	3	4
CR	CL	06	H

1	2	3	4
Model Number CR	Contaminant type		Connector
	AS = Arsenic CL = Chloride CO = Color and Odor PB = Lead MO = Molybdate NI = Nickle SL = Selenium SO = Sulfate VA = Vanadium		
	Length		
	04 = 4 inch 06 = 06 inch 08 = 08 inch 14 = 14 inch 16 = 16 inch		H = Hex B = Barbed R = Round

CX Series Hex Cartridge Dimensions, Weight and Flow Rate Compatibility

Cartridge I.D./ Size	A (inch)	B (inch)	C (inch)	D (inch)	Weight (lbs)	Connector Config.	Connection Type	Connection Size (inch)	Max Flow Rate (GPM)	Max Pressure Rating at 90°C (psi)
CR-XX-04H	4.7	5.5	2.3	2.4	0.46	Hex	FNPT	0.25	1.0	40
CR-XX-06H	5.2	6	2.3	2.4	0.65	Hex	FNPT	0.25	1.3	40
CR-XX-08H	7.1	8	4.5	4.5	2.50	Hex	FNPT	0.50	2.0	40
CR-XX-10H	9.5	10.5	4.3	4.5	3.33	Hex	FNPT	0.50	2.0	40
CR-XX-12H	11.5	12.5	4.3	4.5	4.17	Hex	FNPT	0.50	2.0	40
CR-XX-14H	13.1	14	4.5	0.5	5.00	Hex	FNPT	0.50	2.3	40
CR-XX-16H	15.5	16.5	4.38	0.5	6.10	Hex	FNPT	0.50	2.5	40
CR-XX-18H	17.5	18.5	4.3	4.5	6.98	Hex	FNPT	0.50	2.8	40
CR-XX-20H	19.5	20.5	4.3	4.5	7.85	Hex	FNPT	0.50	3	40
CR-XX-22H	21.5	22.5	4.3	4.5	8.73	Hex	FNPT	0.50	3.2	40
CR-XX-24H	23.5	24.5	4.3	4.5	9.60	Hex	FNPT	0.50	3.4	40

CR Series

Cartridge Product Selection Guide

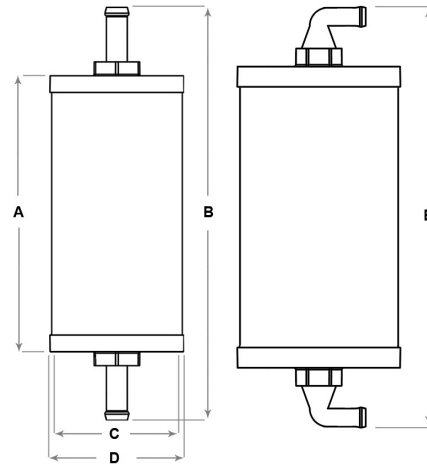

Model Number	Contaminant	Length	Connector	Angle I.D.
1	2	3	4	5
CR	CL	06	B	0

Connection Angle	I.D.
0°	0
90°	1
180°	2

Example of ordering a barbed connection with a 0° connection angle.

CX Series Cartridge Dimensions, Weight and Flow Rate Compatibility

Cartridge I.D./ Size	A (inch)	B (inch)	C (inch)	D (inch)	Weight (lbs)	Connector Config.	Tube Size (inch)	Connection Direction	Angle Between Connector	Max Flow Rate (GPM)	Max Pressure Rating at 90°C (psi)
CR-XX-04BX	4.8	7.1	2.3	2.4	0.46	Barbed	3/8	0°	-	1.0	40
CR-XX-06BX	5.2	7.6	2.3	2.4	0.65	Barbed	3/8	0°	-	1.3	40
CR-XX-08BX	7.5	11.0	4.3	4.5	2.50	Barbed	1/2	90°	0,1,2	2.0	40
CR-XX-10BX	9.5	12.5	4.3	4.5	3.33	Barbed	1/2	90°	0,1,2	2.0	40
CR-XX-12BX	11.5	14.5	4.3	4.5	4.17	Barbed	1/2	90°	0,1,2	2.0	40
CR-XX-14BX	13.1	16.5	4.5	0.5	5.00	Barbed	1/2	90°	0,1,2	2.3	40
CR-XX-16BX	15.5	18.5	4.38	0.5	6.10	Barbed	1/2	90°	0,1,2	2.5	40
CR-XX-18BX	17.5	20.5	4.3	4.5	6.98	Barbed	1/2	90°	0,1,2	2.8	40
CR-XX-20BX	19.5	22.5	4.3	4.5	7.85	Barbed	1/2	90°	0,1,2	3	40
CR-XX-22BX	21.5	24.5	4.3	4.5	8.73	Barbed	1/2	90°	0,1,2	3.2	40
CR-XX-24BX	23.5	26.5	4.3	4.5	9.60	Barbed	1/2	90°	0,1,2	3.4	40

CR Series

Hydraulic Properties: DI Water

— 30°C (86°F) — 50°C (122°F) — 70°C (158°F) — 90°C (194°F)

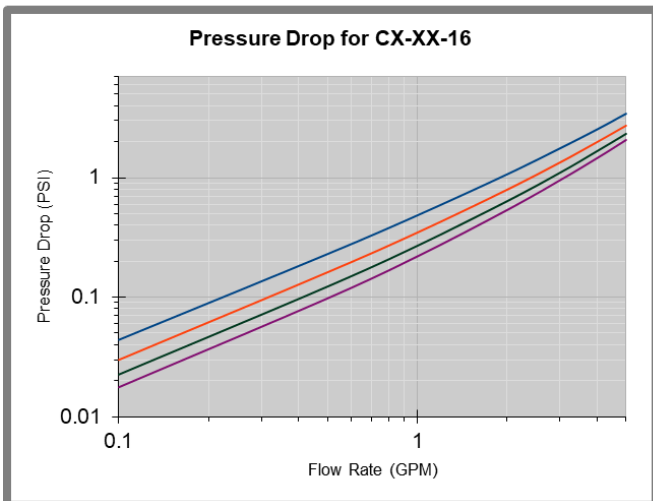
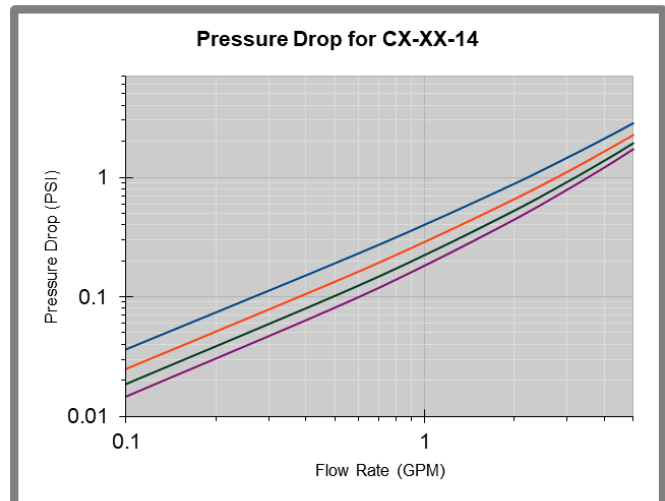
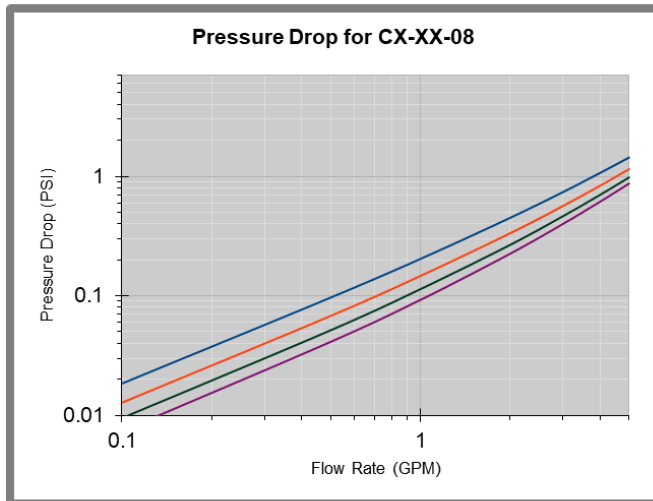
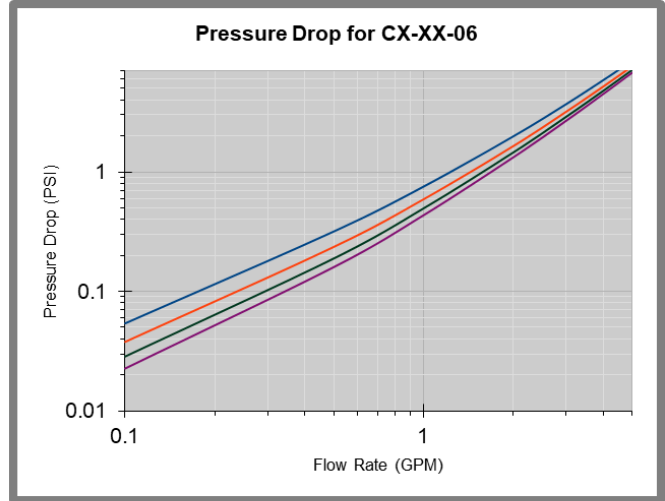
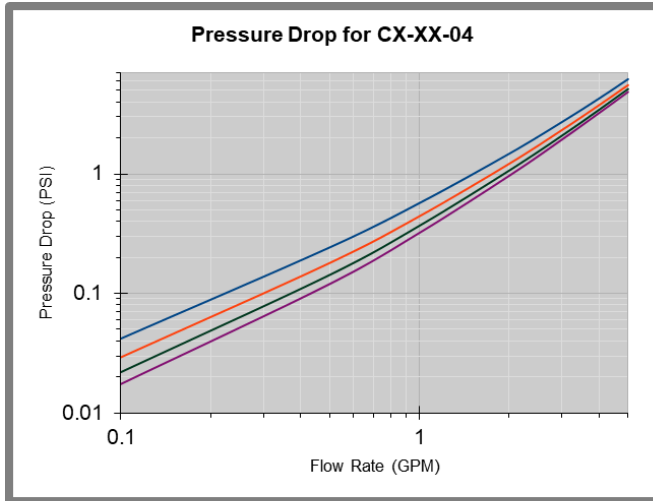

Note:

1. Pressure drop was determined with deionized water.
2. The pressure drop curve is calculated

Series Overview

Dynalene offer deionization system that small laboratory scale applications (1 to 10 GPM) to large industrial application (up to 40 GPM). These systems are designed and tested for maximum ion removal in water.

Applications

- Medical
- Food Processing
- Chemical
- Semiconductor
- DI water making for glycol dilution

Laboratory Scale Application

Low throughput DYI series deionization systems can be easily installed and can be offered for the flow rate of 1 to 10 GPM. These systems can be wall mounted or bought with a stand. These systems are ideal for use in medical, food processing, chemical, and semiconductor based application. The DYI series systems are ideal for making DI water on-site to be blended with glycol to make a glycol-water solution.

DYI series cartridges that are used with these systems are available in various sizes and are designed and tested for maximum ion removal in water. The cartridges can be custom designed to any size and flow rate based on the customer requirement.

Product Description

DYI-22:

DYI-22 deionization system offered by Dynalene is designed and tested for maximum ion removal in water. The system can be easily installed and can provide an output of 1.3 GPM. These systems can be wall mounted or bought with a stand. They are ideal for use in medical, food processing, chemical, and semiconductor based applications. These systems are ideal for making on-site DI water to be blended with glycol to make a glycol-water solution. DYI-22 deionization system can be custom designed to cater to your requirement.

Features:

- Output: 1.3 GPM
- Cartridges not included. Requires two DYI-20 cartridges.
- Mounting stand can be included (optional)
- TDS meter can be added (optional)
- 3/8" inlet/outlet
- Dimension: 16"(width) x 12"(depth) x 33"(height)
- Polypropylene (housing), carbon steel (stand) and PVC (piping) material of construction
- High capacity media
- Performance tested for a long operating cycle
- Longer life
- Compatible with glycol based heat transfer fluid
- Resistant to physical and chemical deterioration
- Easy to install
- Easy to custom design



DYI Series

DYI-44:

The DYI-44 is a four cartridge system which can provide an output of 5 GPM. These system are ideal for use in medical, food processing, chemical, and semiconductor based application. The DYI series systems are ideal for making on-site DI water to be blended with glycol to make a glycol-water solution. These systems are ideal to be used be used with DYI-LO or DYI-20-DI cartridges. These system can be custom designed to cater to your requirement.

Features:

- Output: 5 GPM
- Does not include cartridge and can be bought separately
- Includes 4 polypropylene filter housing.
- Includes 1 fiber glass stand assembly
- TDS meter can be added (optional)
- 1" inlet/outlet
- Dimension: 35"(width) x 18"(depth) x 44"(height)
- Polypropylene (housing), fiberglass (stand) and PVC (piping) material of construction
- High capacity media
- Performance tested for a long operating cycle
- Longer life
- Compatible with glycol based heat transfer fluid
- Resistant to physical and chemical deterioration
- Easy to install



DYI-20:

DYI-20 cartridges are used with the DYI-22 and DYI-44 deionization systems. DYI series deionization systems offered by Dyalene. These cartridges are available in various sizes and are designed and tested for maximum ion removal in water. The cartridges can be custom designed to any size and flow rate based on the customer requirement.

Features:

- 158°F (70°C) Maximum operating temperature
- Dimension: 4.5" diameter x 20" height
- Polypropylene material of construction
- High capacity media
- Performance tested for a long operating cycle
- Longer life
- Compatible with glycol based heat transfer fluid
- Resistant to physical and chemical deterioration
- Easy to install
- Easy to custom design



DYI Series

Industrial Application

High throughput DYI series deionization systems can be offered for the flow rate of up to 40 GPM. These systems can be used as a fixed or a mobile DI water making applications. These large scale DYI series systems are ideal for making on-site DI water to be blended with glycol to make a glycol-water solution in large quantities. It can also be used to make DI water for system flushing applications, large scale manufacturing, and processing applications. We can custom design and build the DI water systems to cater to your requirements.

Deionized water (DI water, DIW or de-ionized water) is water that has almost all of its mineral ions, such as cations like sodium, calcium, iron, and copper, and anions such as chloride and sulfate removed. DI Water is the water of choice in many factories and manufacturing settings. It is commonly used in medical, food processing, chemical and semiconductor industries including, industrial cooling applications and manufacturing of cosmetics.

Dynalene recommends blending deionized water with glycol to make a glycol-water solution to maximize the performance of the fluid and the system. It is recommended that the total chloride and sulfate content in the dilution water should be below 25 ppm to minimize potential corrosion. Hard minerals and salts in dilution water can increase metal corrosion, cause formation of scale deposits, interfere with inhibitor protection, and clog system components. If mixing on-site, a handheld refractometer or hydrometer can be used to check the propylene glycol concentration.



Customization

Along with the standard products, we can also custom design DI systems that meet your requirements. Contact us today at [610.262.9686](tel:610.262.9686) or email at info@dynamene.com and discuss your application with Dynalene's contamination removal experts today.

Glycol Regeneration

Introduction

Dynalene offers glycol regeneration system that can remove both particulate and ionic contaminants in glycol-based heat transfer fluids. These systems can be used in a slipstream or in the main loop for continuous contamination removal without having to stop the existing process. Dynalene's systems can remove ionic contaminations such as chloride, molybdate, calcium, magnesium, sulfate, acetate, selenium, arsenic, and more.

Dynalene's chloride removal system can be used in a variety of applications, such as natural gas storage and extraction, cooling loops in power plants, and applications where heat transfer fluid is contaminated with an ionic compound (i.e. salts). High chloride concentration in heat transfer fluid can cause corrosion, system clogging with salts, reduction in heat transfer efficiency and can sometimes lead to system shutdowns. Our system helps to maintain a very low chloride level while the existing process is still in operation, so that costly shutdowns and maintenance are avoided.

Dynalene's comprehensive filtration solutions are compatible with most heat transfer fluids. The filtration products are available in various sizes, each with customization options like materials of construction, fluid handling capacity, and flow rate. These filters are designed and tested to be used with glycol based fluids like propylene glycol, ethylene glycol, and triethylene glycol, and can be custom built for any application.

Glycol-based heat transfer fluid can become fouled for various reasons after circulating in a system for an extended time. Contamination issues can be caused due to particulates or ionic contaminants that are dissolved in the glycol-water mixture. Some common issues that are seen in glycol-based systems are:

- Particulate contamination turns the fluid a darker color and may result in a decrease in heat transfer efficiency.
- Foaming of the heat transfer fluid creates false readings in gauges and sensors.
- Pipe blockage due to corrosion and erosion, which may be caused by corrosive ionic contaminants and particulate contaminants respectively.
- Rust buildup in the pumps due to the presence of corrosion debris in the fluid.
- Presence of metal shavings and solder particles from when the system was built.

Due to our in-house laboratory capabilities and our extensive experience with heat transfer fluids, we can test the fluid samples to determine the amount of contaminants and the effect that they may have on your system. Contact us today at 610.262.9686 or email at info@dynalene.com and let us help you determine the best contamination removal product that will work for your application. Additionally, we also offer basic testing devices that can be used for fluid property measurements in order to monitor the health of your fluids.

Triethylene Glycol (TEG) Regeneration in Natural Gas application

Natural gas is usually stored underground, in large storage reservoirs. There are three main types of underground storage: depleted gas reservoirs, aquifers, and salt caverns. Though most of the storage in the United States is a depleted gas reservoir, the ability to perform several withdrawal and injection cycles each year provide salt caverns a unique advantage over the rest of the storage techniques [1].

Natural gas, when withdrawn from the underground storage reservoirs, contains moisture; therefore, TEG dehydration towers are used to remove moisture from the natural gas. The moisture in the natural gas contains earthy salts and minerals such as chlorides, silica, sulfate, iron, and others. These salts and minerals remain in the glycol after water is removed through re-boiling. Over time, the concentration of salts increase in the glycol fluid leading to several efficiencies and technical related issues. Higher concentration of chloride in the TEG can cause corrosion of the equipment, create hot spots on the fire tube, increase glycol degradation, increase chances of clogging, lower pH and decrease the dehydration efficiency, leading to periodic glycol change-out [2].



The increase in salt concentration in TEG can be predominantly noticed in salt cavern based natural gas storage facilities.

Glycol Regeneration

Storage sites also experience an increase in salt concentration in TEG during an unexpected increase in moisture infusion during withdrawal. The moisture may travel all the way to the dehydration system due to malfunctioning of the slug catcher and coalition filters.

An ion exchange process can be used to remove the ionic salt contaminants and bring the contaminant level below the acceptable level. In an ion exchange process, a chemical reaction is used to remove the dissolved salt ions in the TEG and the unwanted ions in the fluid is replaced with similarly charged ions from ion exchange media. Due to simple operational technique, the ion exchange based glycol reclamation can be carried out while the plant is operational and does not require handling of the caustic solution.

Features:

- Process will not require handling chemical or caustic solution.
- No electrical power or any source that can cause spark is required for the operation of the contamination removal system.
- Process does not require collection and disposal of waste byproduct
- Easy handling and simple operational procedure that will require minimum monitoring by the operation personnel.
- Pallet mounted system that can be moved using a forklift.
- On-site contamination removal solution that can be connected to the dehydration system without needing to transport the fluid away from the site.
- 10 to 15 gallons per minute fluid reclaiming capability. The flow rate capability can be increased by connecting additional regeneration skids in parallel.
- The contamination removal system is pallet mounted so that it can be moved easily using a forklift.
- The equipped contains particulate filters to remove the particulate contaminants in the fluid.

Functional value:

- The TEG reclamation can be achieved while the dehydration system is operational by connecting the CRS in a slip stream. The contamination removal does not require the fluid to be transported offsite for reclamation.
- Along with chloride removal, the CRS can also be extended to remove other ionic salt contaminants such as sodium, iodide, sulphate, nitrate, phosphate, potassium, molybdate, selenium, arsenic, etc.
- The contamination removal operation does not require handling of caustic solution or disposal of hazardous waste.

Economical value:

- Continuous contamination removal can help avoid plant shutdown due to high chloride levels in the TEG.
- Reclaiming the glycol at the site can help prolong the life of the TEG. Hence reducing the operational cost by avoiding purchasing virgin glycol.
- Keeping the fluid free of ions that cause corrosion can help reduce the equipment service cost.

[1] S Energy Information Administration "The Basics of Underground Natural Gas Storage" Release Date: November 16, 2015.

[2] Gas Processors Suppliers Association Handbook(2008), 10th edition



Email: info@dynalene.com
Phone: 610.262.9686 / 1.877.244.5525
Fax: 610-262-7437
Web: www.dynalene.com

Headquarters:
5250 W. Coplay Road Whitehall,
Pennsylvania 18052

©2020 Dynalene Inc
All Rights Reserved
Printed in USA
February 2020